

Main Components

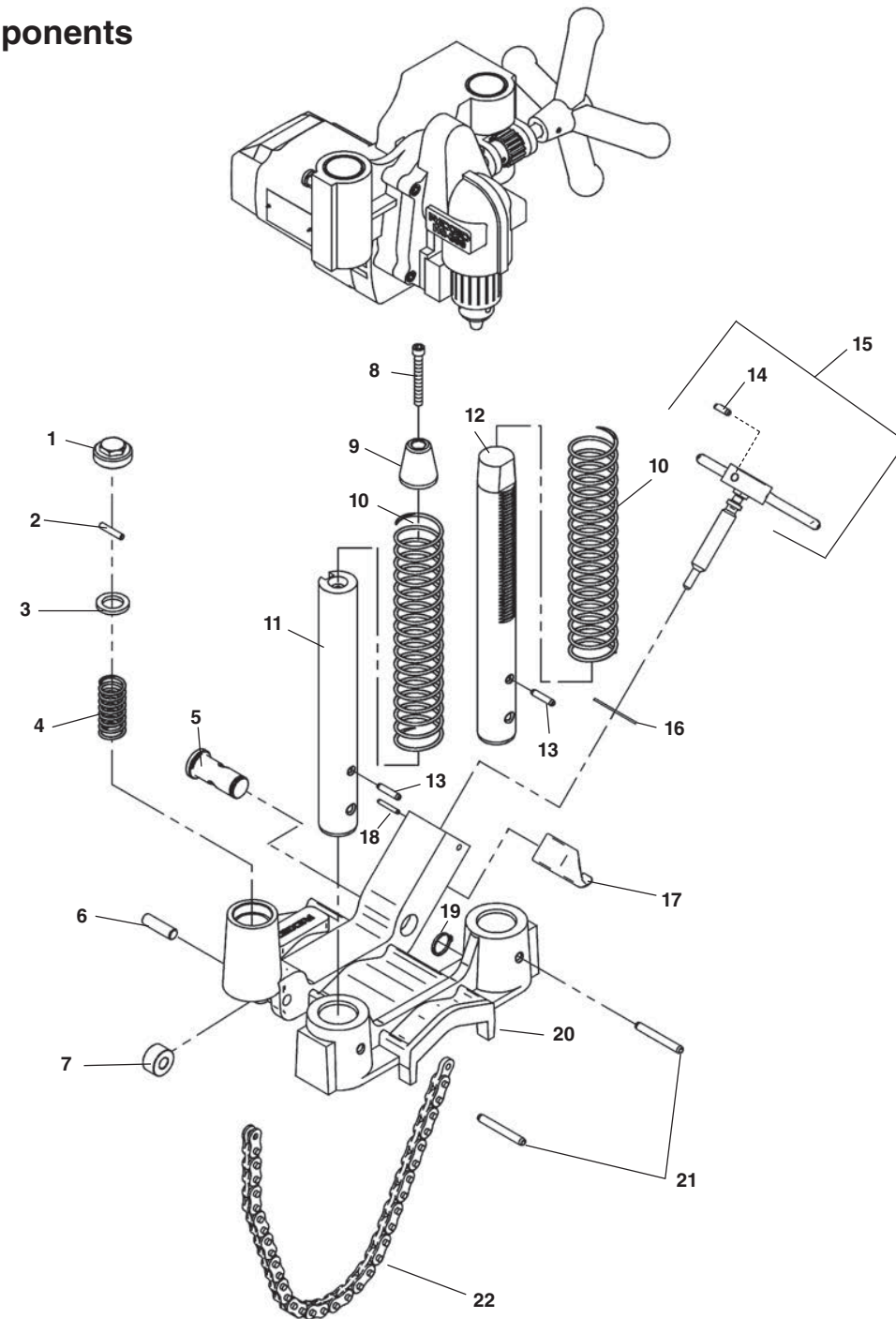

**NOTE: Order parts by Catalog Number only.
DO NOT order by Reference Number.**

Ref. No.	Catalog No.	Description	Ref. No.	Catalog No.	Description
1	77092	Cap	12	77052	Rack w/Pins (Incls. Refs. 13, 21)
2	77097	Pin	13	34342	Spring Pin (2)
3	77242	Washer	14	77067	Ball Detente
4	77087	Compression Spring	15	77077	Crank Screw Assembly
5	77257	Pivot Pin	16	77072	Friction Ring
6	41035	Roller Pin	17	77082	Chain Hook
7	40990	Roller	18	76735	Spring Pin
8	32145	Soc. Hd. Cap Screw, 1/4" - 20 x 1 1/2"	19	77252	Retaining Ring
9	77262	Plunger Stop	20	77042	Base w/Pins (Incls. Ref. 21)
10	77057	Compression Spring (2)	21	44850	Spring Pin (2)
11	77047	Post Assembly (Incls. Refs. 8, 9, 13, 21)	22	77247	Chain Assembly (Incls. Ref. 2, 3)

Transmission

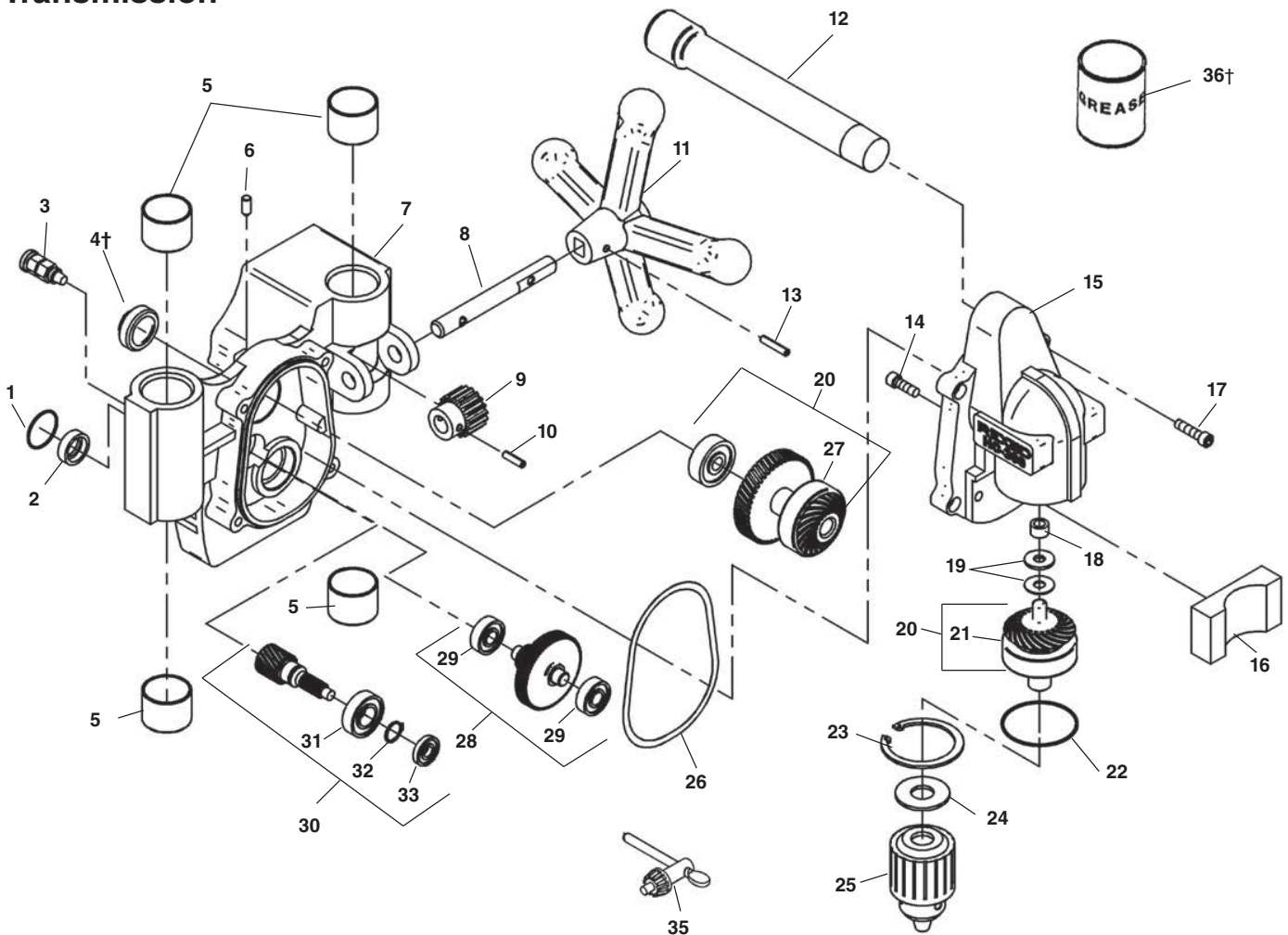

**NOTE: Order parts by Catalog Number only.
DO NOT order by Reference Number.**

Ref. No.	Catalog No.	Description	Ref. No.	Catalog No.	Description	Ref. No.	Catalog No.	Description
1	77202	O-Ring	13	36387	Roll Pin	25	77012	Chuck w/Key
2	77207	Grease Seal	14	40910	Screws (4)	26	77177	Gasket, Transmission
3	61567	Plunger Assembly	15	77142	Front Gear Case	27	45315	Ball Bearing
†4	77092	Adjusting Cap	16	77172	Chuck Guard	28	77112	2nd Intermediate Gear Assembly
5	59027	Bearing (4)	17	83685	Screw (4)	29	77187	Ball Bearing (2)
6	77167	Set Screw, Nylon Tip	18	77122	Needle Bearing	30	77117	1st Intermediate Gear Assembly
7	77147	Rear Gear Case	19	77127	Thrust Bearing Assembly	31	77197	Ball Bearing
8	77007	Feed Shaft	20	77102	Spiral Gear Set	32	83027	Retaining Ring
9	59092	Carriage Pinion	21	45315	Ball Bearing	33	77192	Ball Bearing
10	44662	Roll Pin	22	77157	O-Ring	†34	26707	Transmission Grease, 1 Lb.
11	58957	Hand Wheel	23	77132	Retaining Ring, Internal	35	77017	Chuck Key
12	77152	Carry Handle	24	46295	Spacer			

† Service Notes:

Ref. 4 Backlash Adjustment – Use 6" C-Clamp to lightly push chuck into housing. Apply thin coat of Loctite No. 545 Hydraulic/Pneumatic Thread Sealant (or equivalent) to threads on adjusting cap, Ref 4. Tighten cap to 40 - 50 in-lbs then back off to eliminate torque. Re-tighten finger tight then back off 20° to 30°. Remove clamp and check by gripping chuck with fingertips and feeling for minimal rotational backlash in output gear. Tighten set screw, Ref. 6, to hold cap securely.

Ref. 36 Grease Fill – Use only recommended transmission grease (Molytex EPO). Fill bearing pockets with grease and apply coating to gear teeth. Fill two separate transmission cavities approximately 1/2 full of grease using about 1/4 of pound can

Motor Type 2

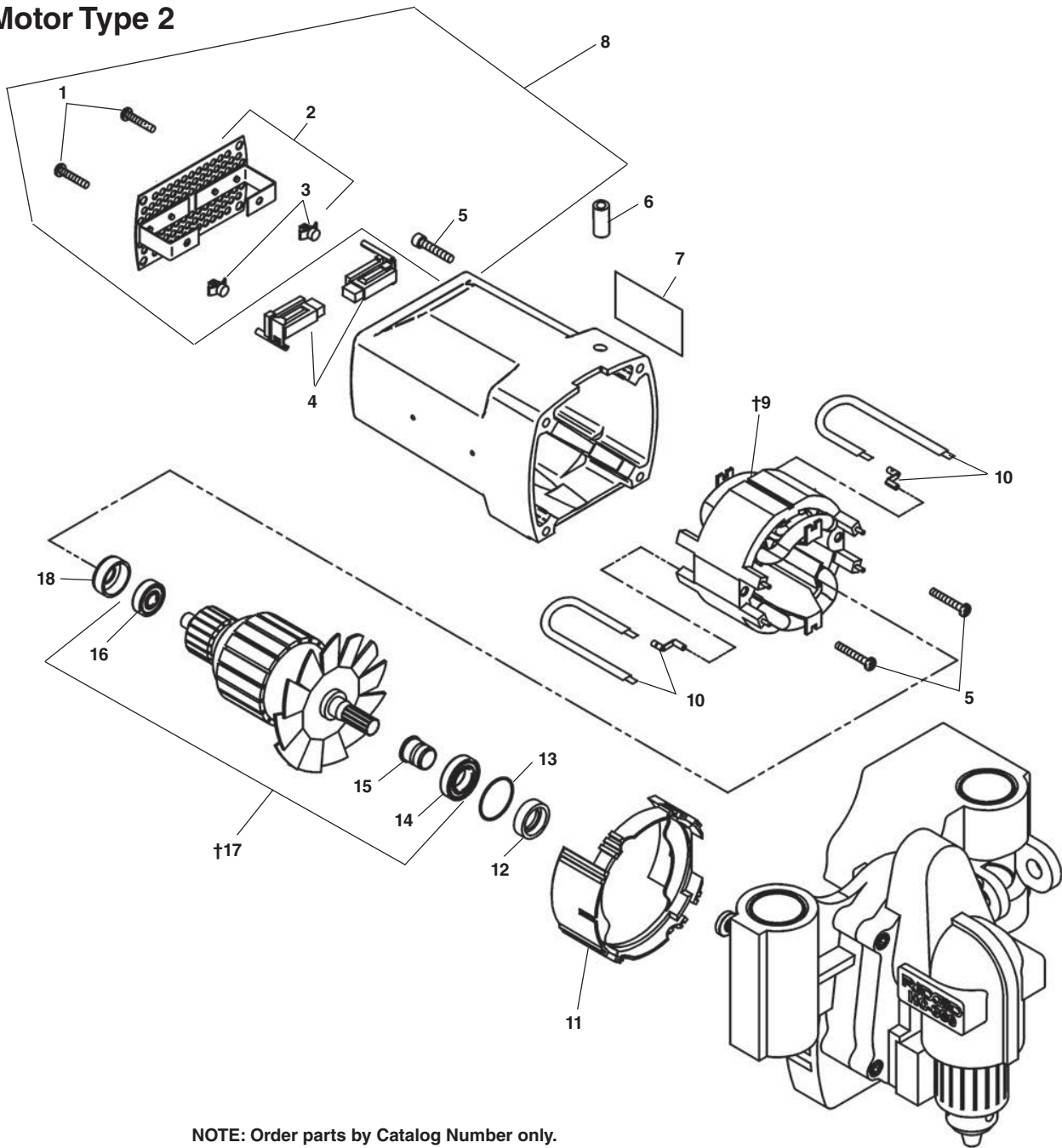

**NOTE: Order parts by Catalog Number only.
DO NOT order by Reference Number.**

Ref. No.	Catalog No.	Description	Ref. No.	Catalog No.	Description
1	10908	Screw, Self Tapping (4)	10	77027	Motor Lead Set
2	10913	End Cap	11	35328	Fan Shroud
3	10918	Bumper (2)	12	77207	Seal
4	34078	Brush Assembly Set 115V	13	77202	O-Ring
	34083	Brush Assembly Set 230V	14	77232	Bearing
5	10923	Screw, #10-24 x 2" Soc. Hd. Cap (6)	15	77227	Armature Sleeve
6	10928	Insulator	16	43017	Bearing
7	77267	Warning Label Set	†17	84087	Armature Assembly 115V
8	22038	Motor Housing		84082	Armature Assembly 230V
†9	45897	Field 115V		84092	Armature Assembly 100V
	58567	Field 230V	18	42777	Rubber Sleeve
	58572	Field 100V			

† Service Note: When replacing early style 115V or 230V armature# or field# you must replace with both new style armature#, field# and brushes#.

Motor Type 2 – Motors built after serial number EBH XXXXX 1109

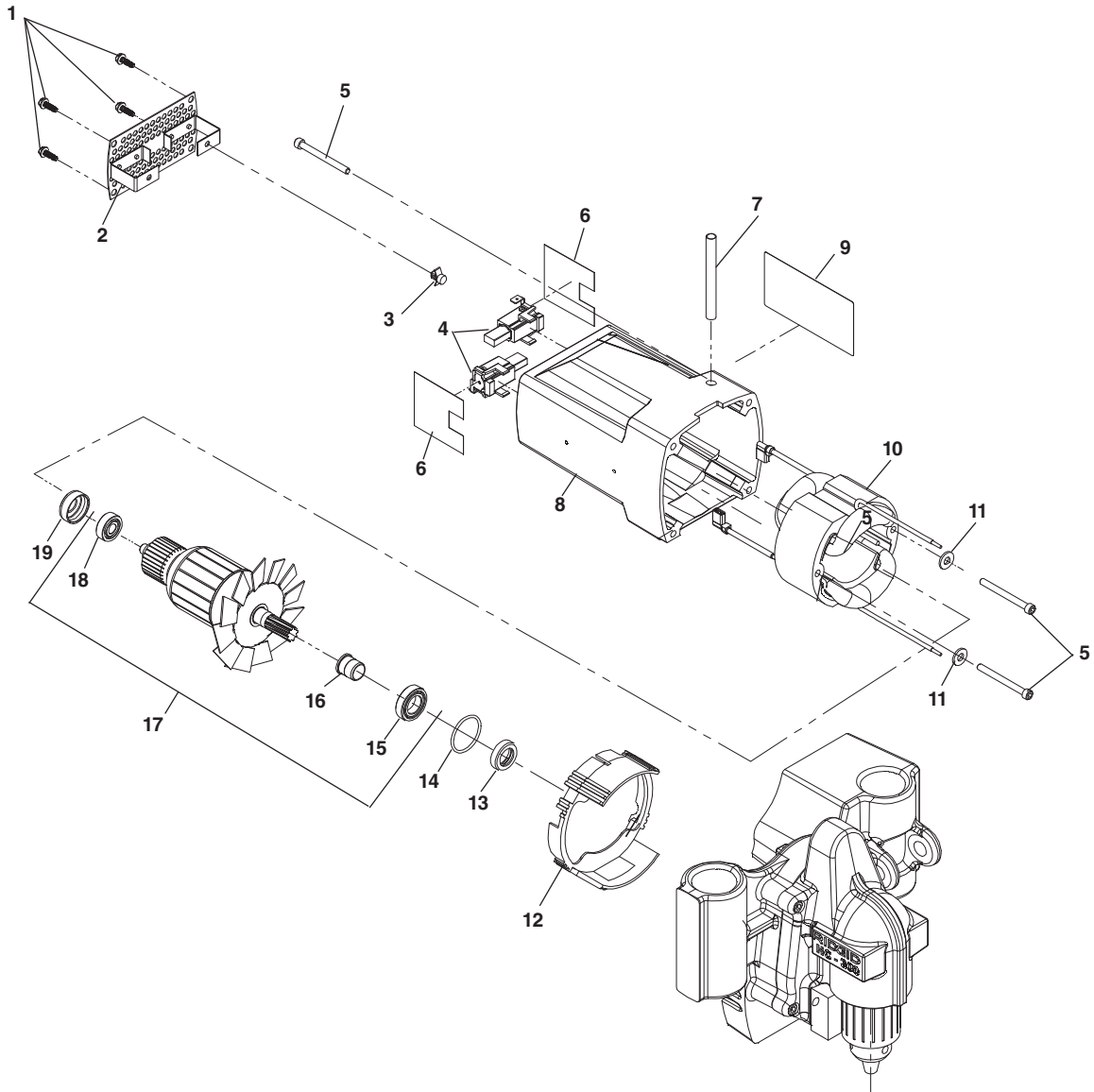

**NOTE: Order parts by Catalog Number only.
DO NOT order by Reference Number.**

Ref. No.	Catalog No.	Description	Ref. No.	Catalog No.	Description
1	10908	Screw, Self Tapping (4)	11	41592	Washer
2	10913	End Cap	12	35328	Fan Shroud
3	10918	Bumper	13	77207	Seal
4	34078	Brushes	14	77202	O-Ring
5	10923	Screw, #10-24 x 2" Soc. Hd. Cap (6)	15	77232	Bearing
6	39003	Shields (2)	16	77227	Armature Sleeve
7	10928	Insulator	17	38833	Armature Assembly 120V
8	22038	Motor Housing HC-300		38838	Armature Assembly 220V
9	77267	Warning Label Set		38843	Armature Assembly 100V
10	38848	Field 115V	18	43017	Bearing
	38853	Field 220V	19	42777	Rubber Sleeve
	38858	Field 100V			

115V Components

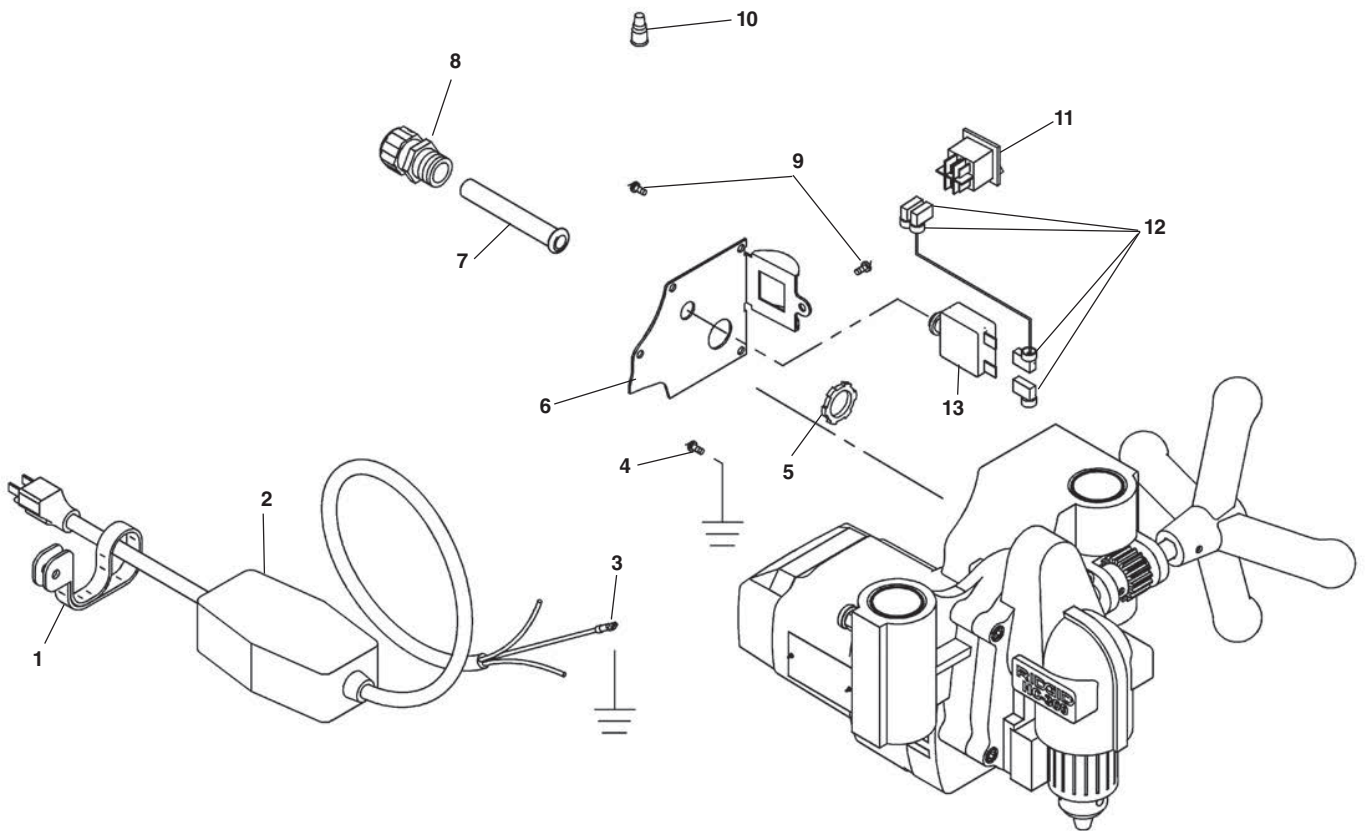

**NOTE: Order parts by Catalog Number only.
DO NOT order by Reference Number.**

Ref. No.	Catalog No.	Description	Ref. No.	Catalog No.	Description
1	59102	Key Retainer	8	65602	Strain Relief
2	50502	Line Cord w/GFI	9	46795	Screw #10 - 24 x 1/2" (5)
3	26292	Ring Terminal	10	44635	Wire Nut
4	45420	Screw w/Washer	11	58597	Switch
5	65642	Lock Nut, 1/2" NPT	12	76992	Quick Disconnect, Right Angle (4)
6	87047	Switch Box Cover	13	61302	Circuit Breaker, 12 Amp
7	77002	Cord Guard			

230V Components

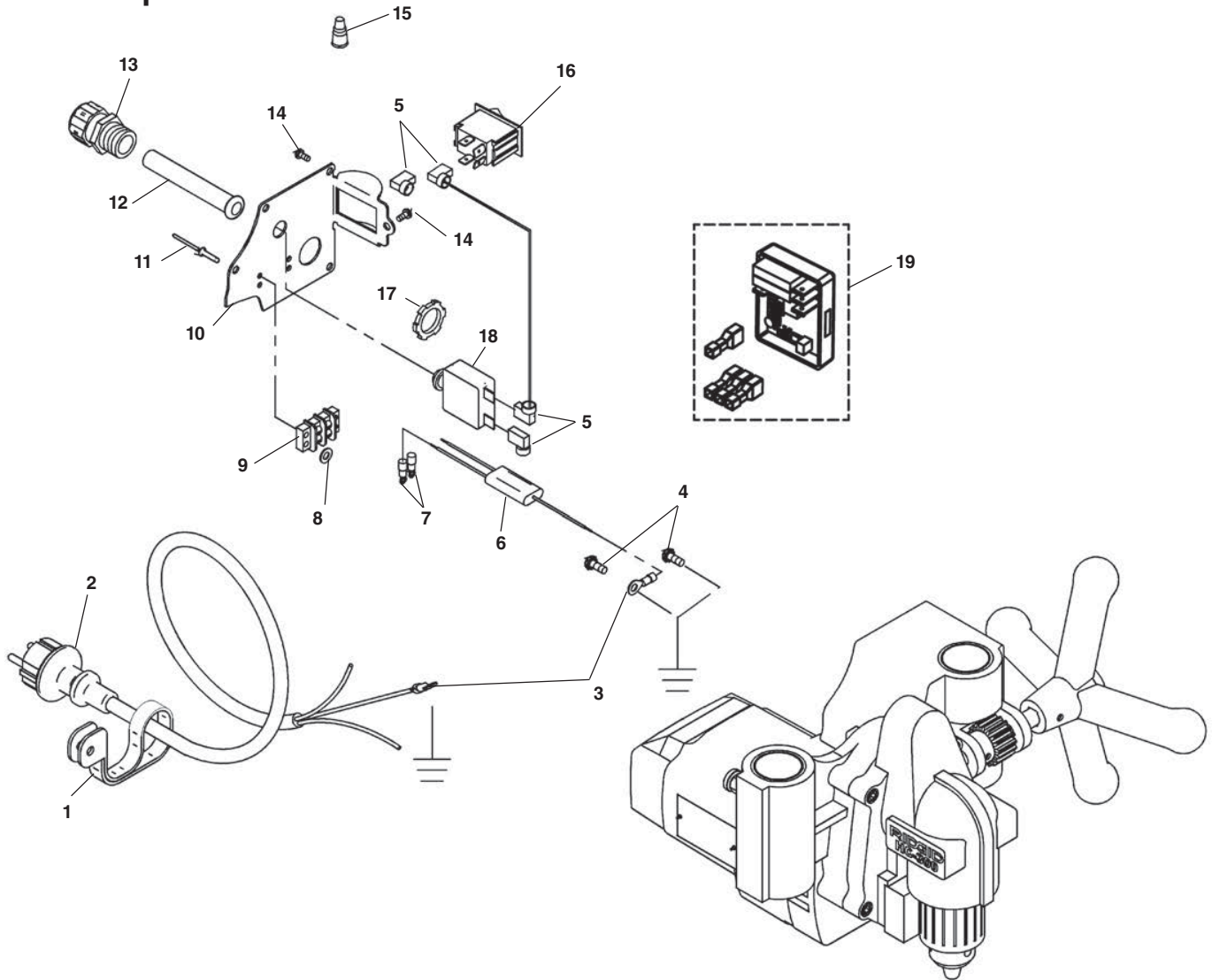

**NOTE: Order parts by Catalog Number only.
DO NOT order by Reference Number.**

Ref. No.	Catalog No.	Description	Ref. No.	Catalog No.	Description
1	59102	Key Retainer	11	59112	Pop Rivet 5/32" (2)
2	65842	Line Cord	12	77002	Cord Guard
3	26292	Ring Terminal	13	65602	Strain Relief
4	45420	Screw w/Washer (2)	14	46795	Screw #10 - 24 x 1/2" (5)
5	76992	Quick Disconnect, Right Angle (4)	15	44635	Wire Nut
6	36502	Suppressor	16	59597	Switch
7	90807	Ring Terminal (2)	17	65642	Lock Nut, 1/2" NPT
8	90817	Washer	18	59357	Circuit Breaker, 6 Amp
9	59367	Terminal Block	19	39318	230 V Soft Start Assy.
10	87052	Switch Box Cover			

100V Components

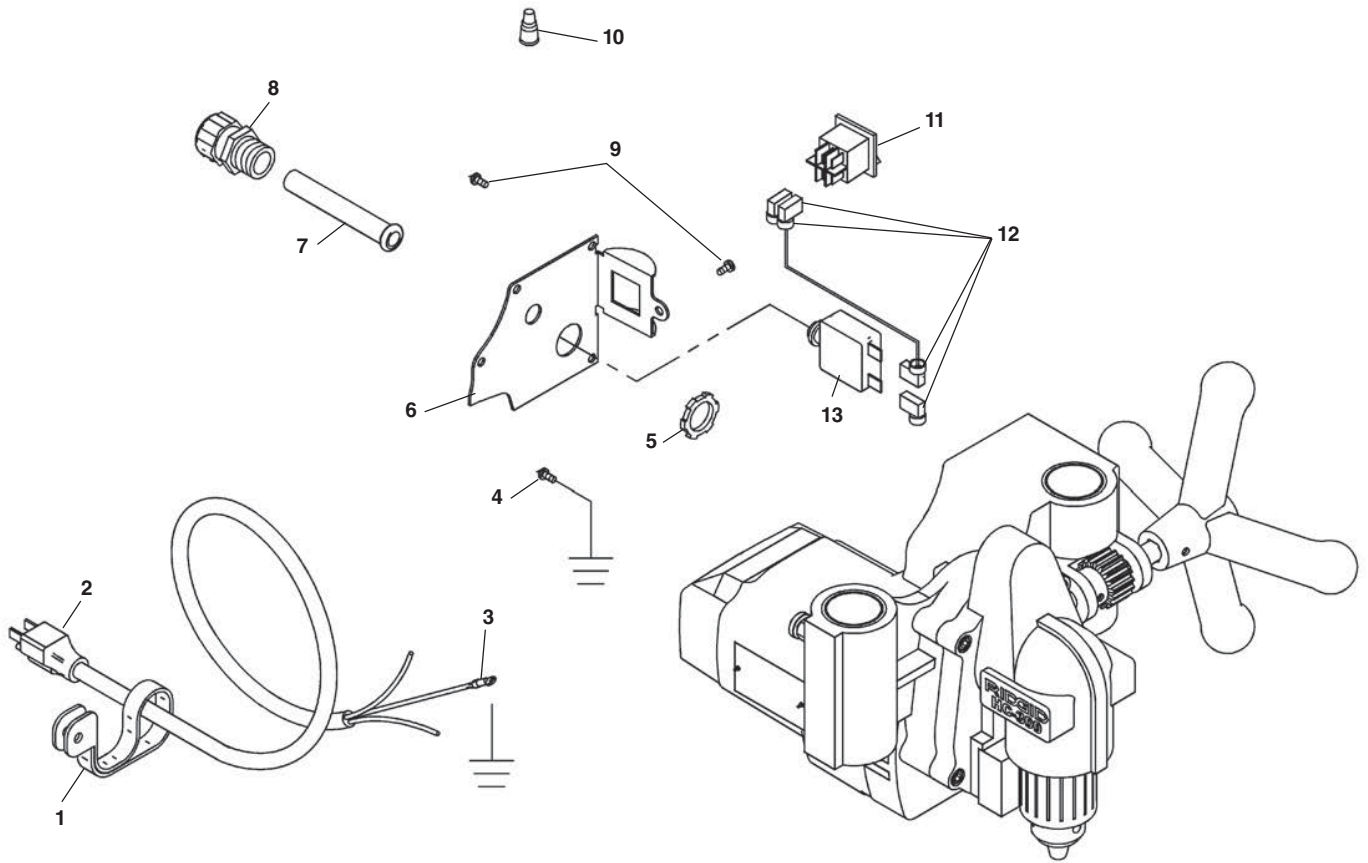

**NOTE: Order parts by Catalog Number only.
DO NOT order by Reference Number.**

Ref. No.	Catalog No.	Description	Ref. No.	Catalog No.	Description
1	59102	Key Retainer	8	65602	Strain Relief
2	89155	Line Cord	9	46795	Screw #10 - 24 x 1/2" (5)
3	26292	Ring Terminal	10	44635	Wire Nut
4	45420	Screw w/Washer (2)	11	58597	Switch
5	65642	Lock Nut, 1/2" NPT	12	76992	Quick Disconnect, Right Angle (4)
6	87047	Switch Box Cover	13	58962	Circuit Breaker, 15 Amp
7	77002	Cord Guard			

230V Wiring Diagram

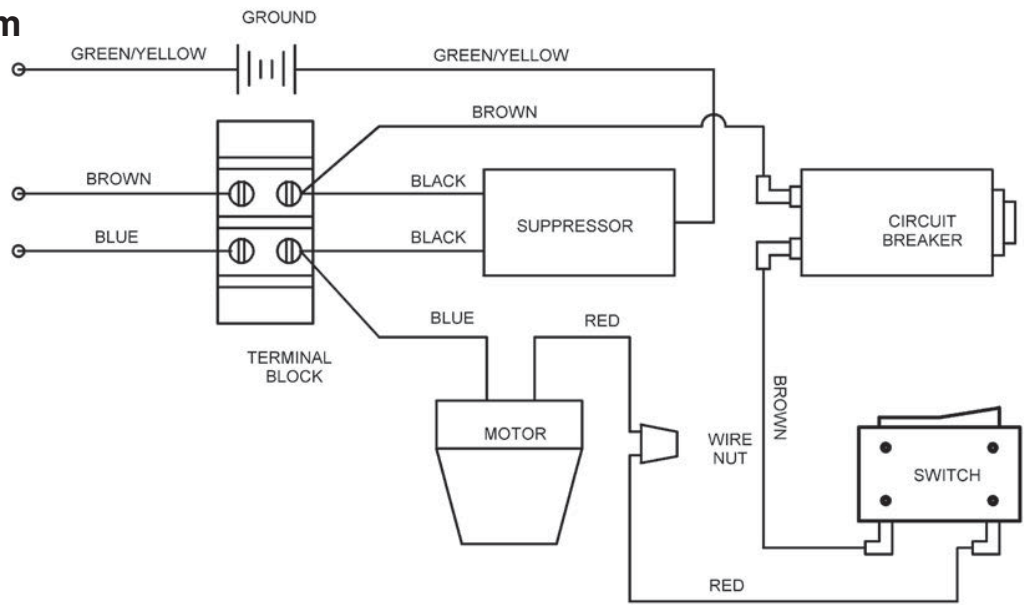

230V Wiring Diagram (w/Soft Start)

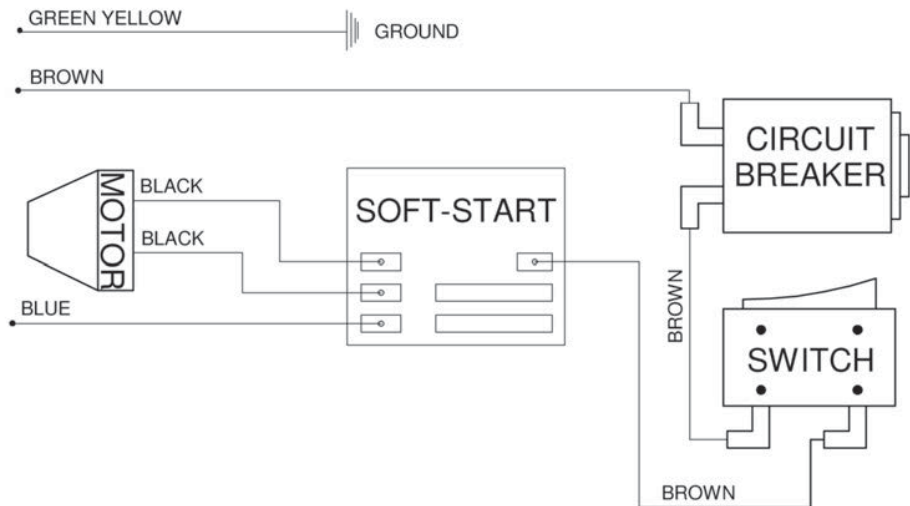

100V/115V Wiring Diagram

