

Main Drive Components

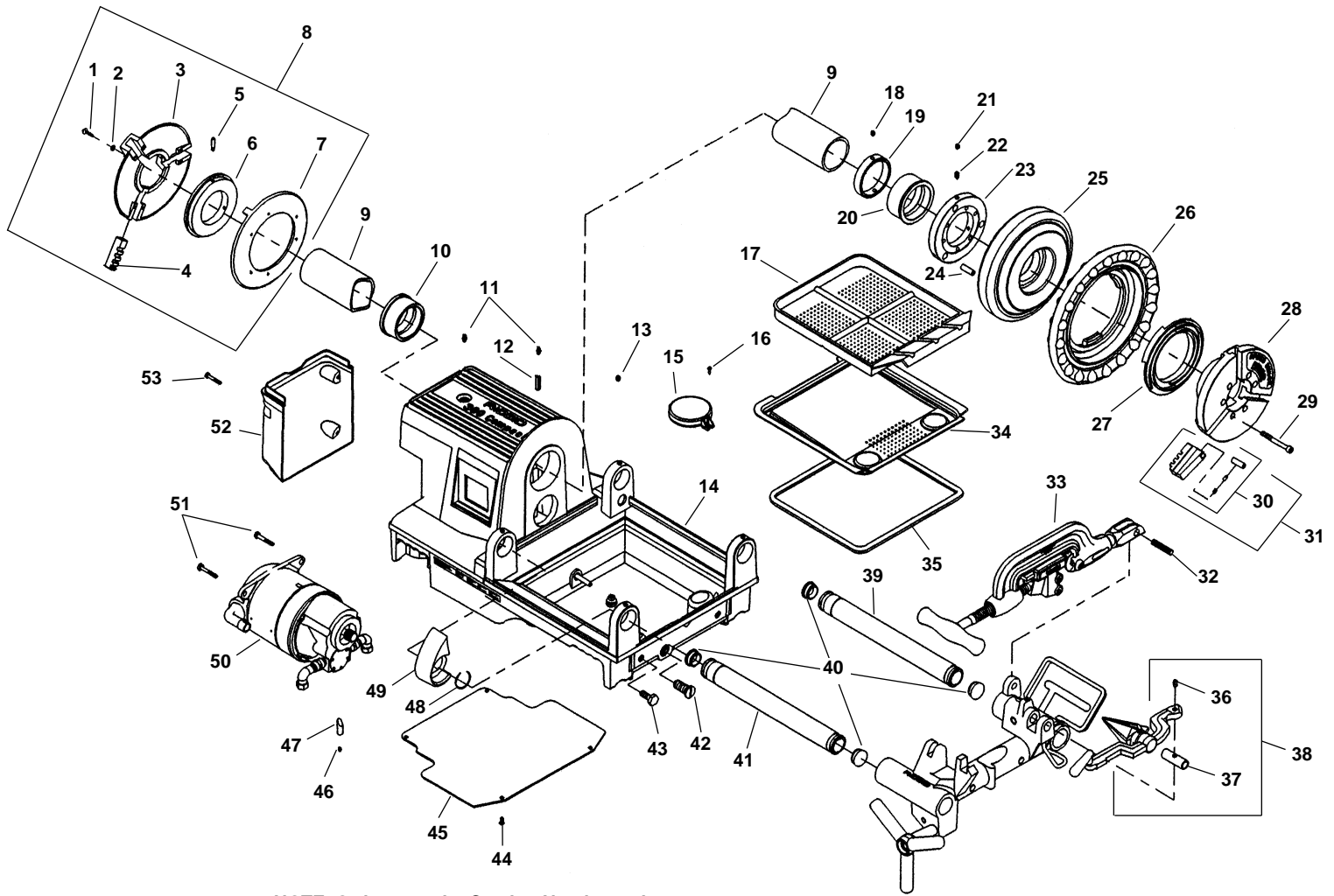

**NOTE: Order parts by Catalog Number only.
DO NOT order by Reference Number.**

Ref. No.	Catalog No.	Description	Ref. No.	Catalog No.	Description	
1	46790	Screw 12 - 24 x 3/4" (6)	29	45295	Screw 5/16" x 2 1/4" (6)	
2	40270	Lock Washer (6)	30	44715	Jaw Insert Set (3)	
3	43735	Rear Centering Head	31	97365	Jaw Insert Set f/Coated Pipe (3)	
4	19346	Rear Centering Head (Europe)	32	44090	Chuck Jaw Set	
5	46500	Rear Jaw	33	45520	Hinge Pin	
6	45260	Step Pin	34	42370	360 Cutter Complete	
7	44095	Scroll	35	54052	Oil Pan Liner	
8	43740	Back Plate	36	75632	Oil Pan Liner Gasket	
9	19356	Back Plate (Europe)	37	36262	Shoulder Screw	
10	44165	Rear Centering Assembly	38	36267	Pivot Pin	
11	44100	Drive Shaft	39	34612	344 Reamer	
12	45335	Rear Bearing	40	54112	Rear Rail	
13	46860	Grease Fitting (2)	41	35162	Rail Plug (4)	
14	88230	Pin Split Roll	42	54117	Front Rail	
15	60025	Set Screw 5/16" - 18 (4)	43	54302	Drain Plug	
16	54522	Base	44	54042	M10-1.5 Hex Hd. Cap Screw	
17	76342	Base N.A.	45	87730	Screw 1/4" x 3/8" (4)	
18	58467	Filter Screen Assembly	46	61937	Bottom Cover	
19	45420	Screw 10 - 24 x 3/8"	47	77905	Set Screw 5/16" x 1/4"	
20	54047	Chip Tray	48	54037	Motor Wedge	
21	33785	Set Screw 5/16" x 24 x 1/2" (3)	49	87620	Retaining Ring	
22	45345	Thrust Ring	50	54507	Carriage Stop	
23	54502	Front Bearing	51	72122	Model 2192, 115V	
24	45300	Set Screw 5/16" x 24 x 1/4" (3)	52	72127	Model 2292, 230V	
25	30027	Drive Ring	53	54797	Model 2192, 115V	
26	30022	Drive Pin (3)		54802	Model 2292R, 230V	
27	30017	Ring Gear		75897	Model 2199R, 115V, 52 RPM	
28	89150	Hand Wheel		51	85915	Motor Mounting Bolt (2)
29	43540	Chuck Scroll		52	54527	Motor Cover
30	43525	Chuck Cap		53	54532	Motor Cover Screw (4)

Carriage and Oil System

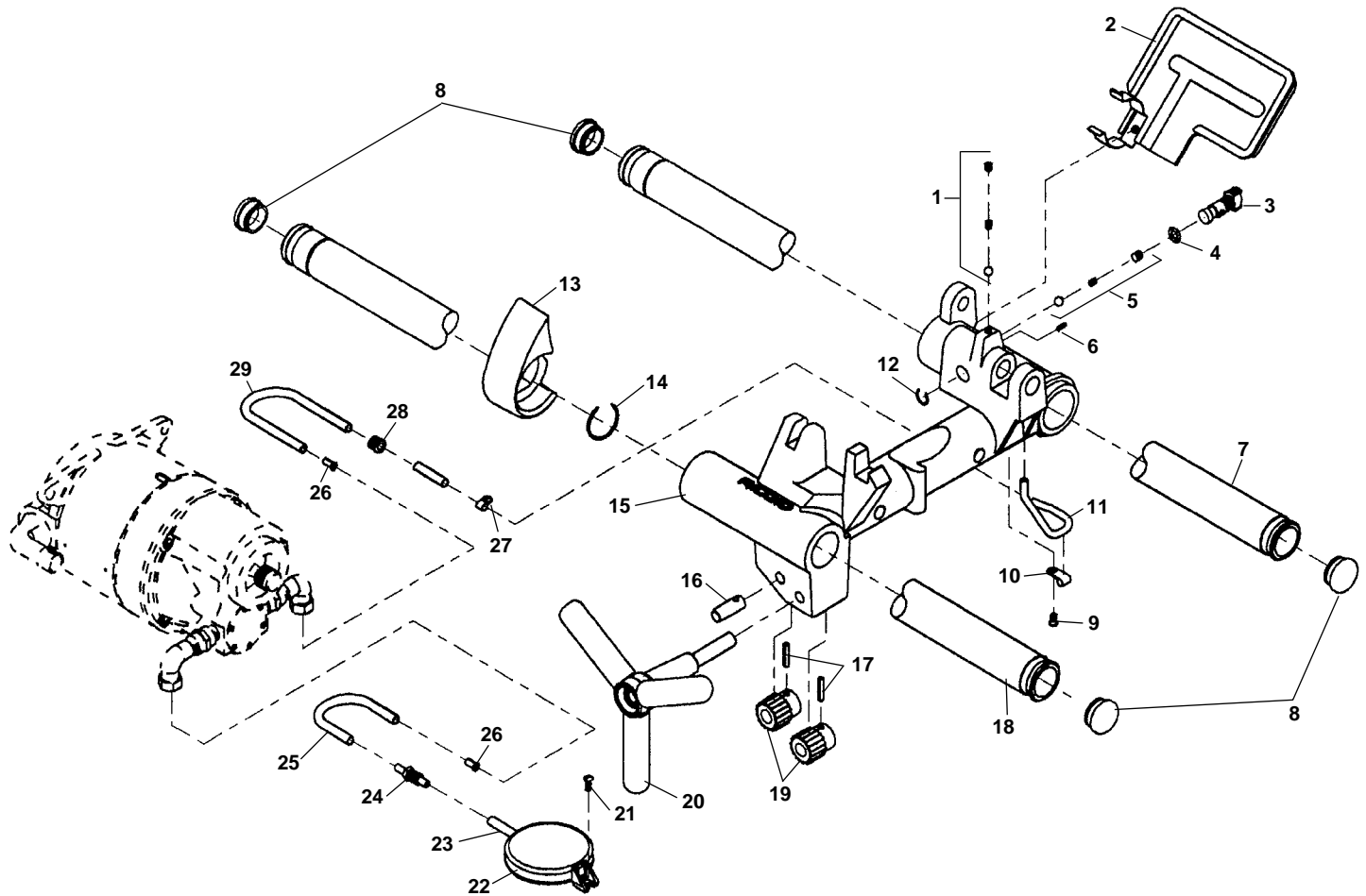

**NOTE: Order parts by Catalog Number only.
DO NOT order by Reference Number.**

Ref. No.	Catalog No.	Description
1	46810	Detente Assembly
2	54517	Drip Pan
3	54097	Spool Valve
4	54102	O-Ring
5	35307	Oil Pressure Relief Set
6	58417	Roll Pin 1/8" x 3/8"
7	54112	Rear Rail
8	35162	Rail Plug (4)
9	79965	Screw 10 - 32 x 1/2"
10	35062	Oil Line Clamp
11	35067	Oil Tube
12	54107	Retaining Ring
13	54507	Carriage Stop
14	87620	Retaining Ring
15	54512	Carriage
16	35187	Pinion Idler Shaft
	54122	Cap Plug (not shown)
17	34342	Roll Pin
18	54117	Front Rail
19	57097	Pinion
20	35182	Hand Wheel
21	45420	Screw 10 - 24 x 3/8"
22	58467	Filter Screen Assembly
23	61897	Oil Filter Tube
24	54142	Bulkhead Fitting
25	54152	Oil Intake Line
26	35117	Oil Line Insert
27	35142	Hose Clamp
28	47080	Oil Line Grommet
29	61282	Carriage Oil Line

Motor

**2192
2292
2192R
2292R**

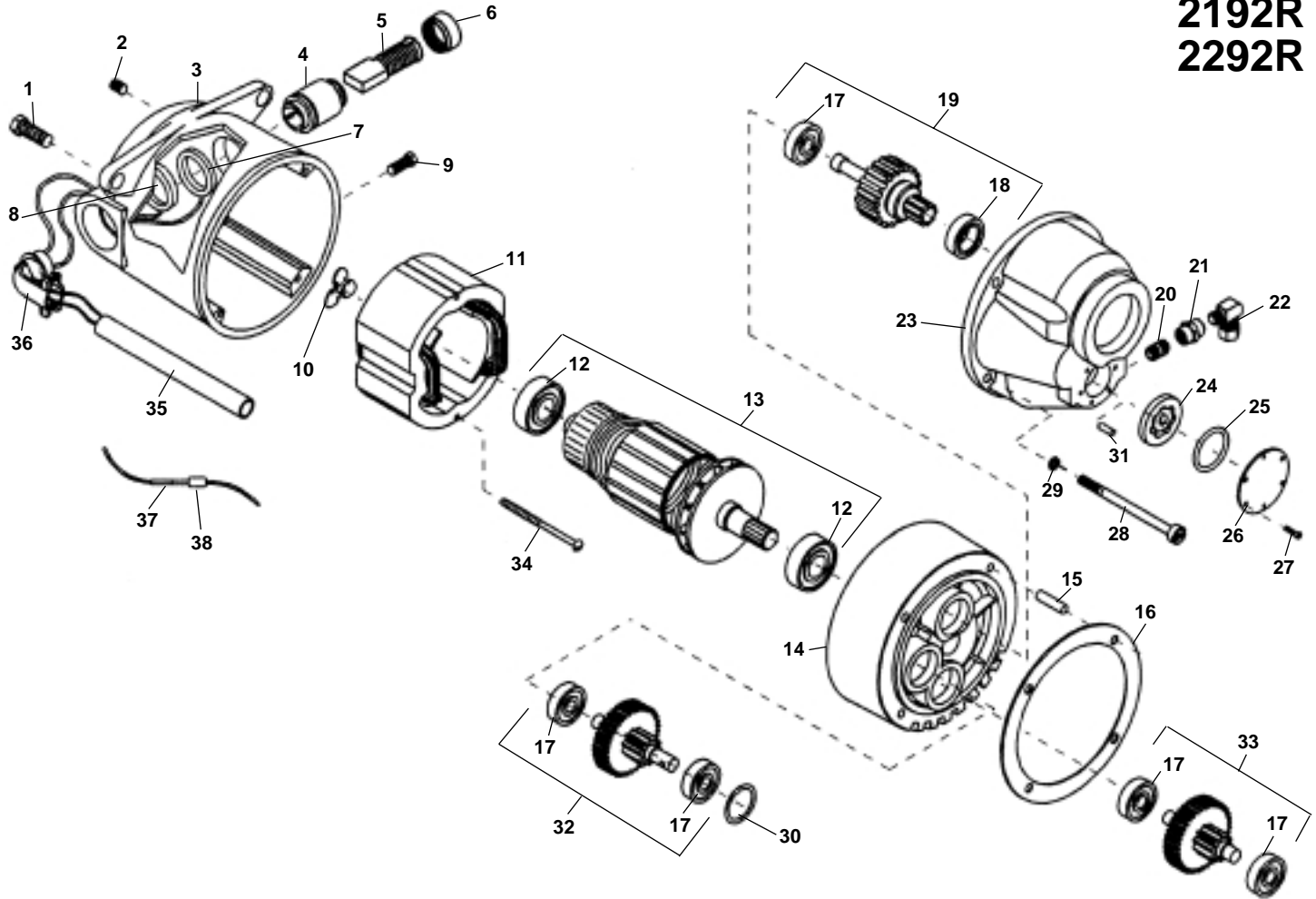

**NOTE: Order parts by Catalog Number only.
DO NOT order by Reference Number.**

Ref. No.	Catalog No.	Description	Ref. No.	Catalog No.	Description	Ref. No.	Catalog No.	Description
—	72122	Motor Model 2192, 115V	12	44565	Armature Bearing (2)	26	96840	Cover Plate
—	72127	Motor Model 2292, 230V	13	52497	115V Armature	27	96890	Screw #4 x 3/8" (6)
—	54797	Motor Model 2192, 115V		54542	230V Armature	28	45075	Screw 1/4" - 20
—	54802	Motor Model 2292R, 230V	14	54552	Fan Housing Assembly	29	45150	Lock Washer 1/4"
1	85915	Motor Mounting Bolt (2)	15	45165	Dowel Pin	30	96880	Oil Seal
2	39770	Set Screw 1/4" - 20 x 1/4" (2)	16	52502	Gasket	31	96885	Pin
3	52482	Motor Housing	17	44760	Gear Bearing	32	52522	1st Gear Assembly
4	45025	Brush Holder Set (2)	18	45315	Front Bearing	33	54547	2nd Gear Assembly
5	44540	Brush Assembly Set (2)	19	54537	Main Drive Gear Assembly	34	44555	Screw 10 - 24 x 3"
6	44545	Brush Cap Set (2)	20	52507	1/8" NPT Close Nipple (2)	35	63382	Plastic Tube
7	86685	Red Brush Lead	21	52512	1/8" Coupling (2)	36	46900	90 Connector
8	86680	White Brush Lead	22	52517	Elbow Compression Fitting (2)	—	47412	Male Wire Connector
9	83500	Field Locking Screw	23	96830	Gear Case	—	52537	Female Wire Connector
10	44580	Loading Spring	24	96870	Gerotor Set	37	16946	Male Connector
11	44015	Field 100/115V	25	96875	"O" Ring	38	16956	Female Connector
	44035	Field 230V						

**Far East
Electrical Components**

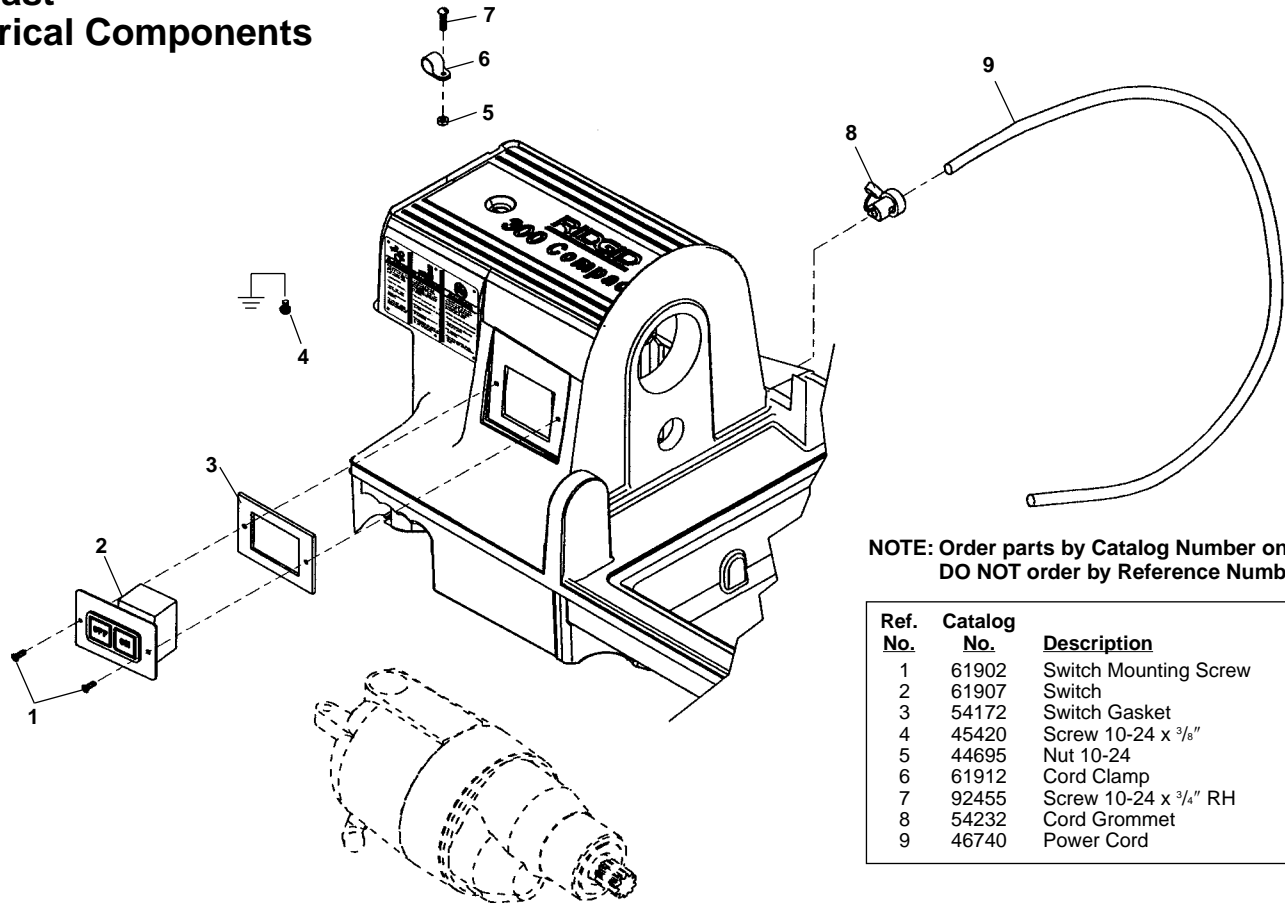

Ref. No.	Catalog No.	Description
1	61902	Switch Mounting Screw
2	61907	Switch
3	54172	Switch Gasket
4	45420	Screw 10-24 x 3/8"
5	44695	Nut 10-24
6	61912	Cord Clamp
7	92455	Screw 10-24 x 3/4" RH
8	54232	Cord Grommet
9	46740	Power Cord

European Electrical Components

Ref. No.	Catalog No.	Description
1	61397	Switch Knob
2	54167	Switch Face Plate
3	54157	Switch & Screws
4	61902	Slotted Pan Head Screw #6 - 32 x 1/2"
5	61917	Switch Plate
6	54172	Switch Gasket
7	63387	Brown Wire
8	63392	Blue Wire
9	63372	Suppressor
—	63387	Brown Lead Wire
—	63392	Blue Lead Wire
10	45420	Screw 10-24 x 3/8"
11	44695	Nut 10-24
12	61912	Cord Clamp
13	92455	Screw 10-24 x 3/4" RH
14	36652	Foot Switch (B-296)
—	40022	Foot Switch f/Aust. (B-299)
—	40017	Foot Switch f/U.K. (B-298)
15	54177	Strain Relief w/Locknut
16	63377	Ferrite Bead
17	43552	Cable Tie

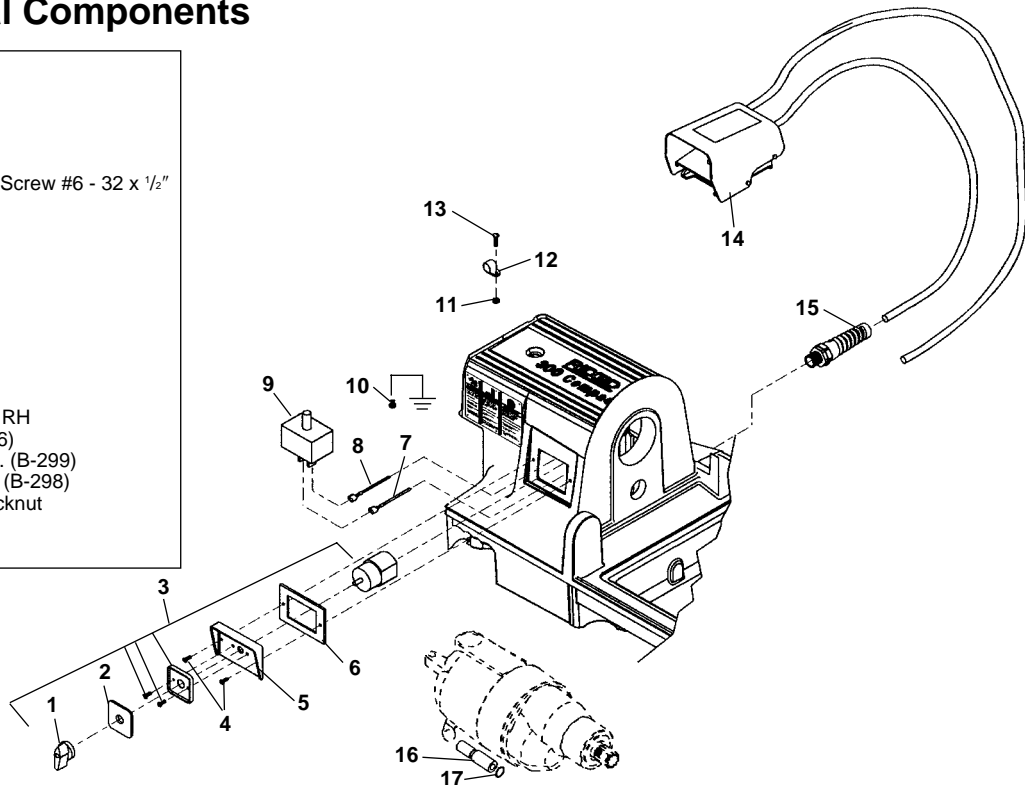

120V 60Hz Electrical

NOTE: Order parts by Catalog Number only.
DO NOT order by Reference Number.

Ref. No.	Catalog No.	Description
1	61397	Switch Knob
2	61967	Switch Face Plate
3	54157	Switch Assembly
4	54162	Screw (2)
5	44695	Switch Plate
6	54172	Gasket
7	45420	Screw #10 - 24 x 3/8"
8	72132	Connecting Cord
9	44695	Hex Nut #10 - 24
10	61912	Cord Retainer
11	92455	Screw #10 - 24 x 3/4"
12	54357	Screw 5/16" - 18 (2)
13	58602	Foot Switch Hook
14	36642	B-294 Foot Switch
15	54137	Screw (2)
16	58267	Foot Switch Hanger Bracket
17	96730	Hex Nut 3/16" - 18
18	72107	Strain Relief
19	46740	Power Cord
20	44635	End Splice Connector

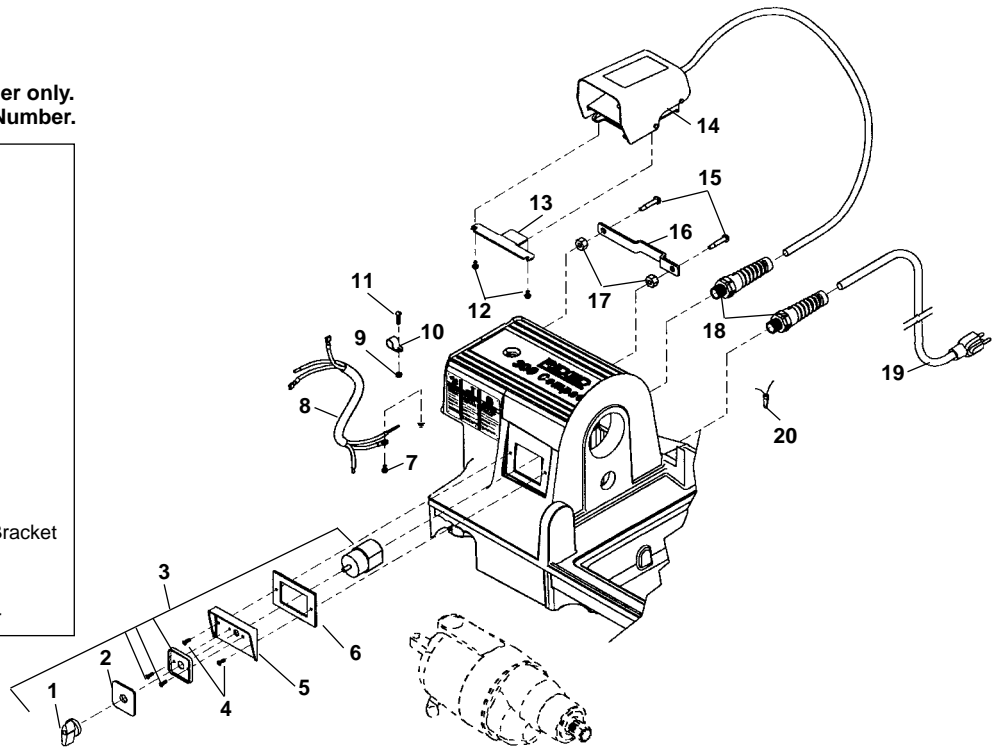

No. 360 Cutter

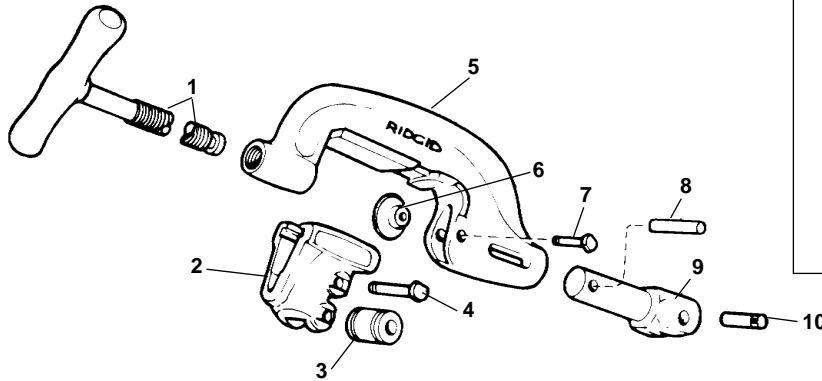

Ref. No.	Catalog No.	Description
—	42370	360 Cutter Complete
1	43625	D-1024-X Screw Handle
2	33400	C-878-X Roll Housing Assembly
3	34305	E-1751 Roll (2)
4	34310	E-1752 Roll Pin (2)
5	43595	C-877 Cutter Frame
6	33100	F-514 Cutter Wheel Thin
	33105	F-3 Cutter Wheel H.D.
	44185	E-1032 Cutter Wheel Std.
7	34780	F-9 Wheel Pin
8	45435	E-3549 Retaining Pin
9	45505	E-3759 Support Arm
10	45520	E-3819 Pin

No. 344 Reamer

Ref. No.	Catalog No.	Description
—	34612	344 Reamer Complete
1	36262	Shoulder Screw
2	36267	Pivot Pin
3	36272	Reamer Arm
4	36277	Reamer Cone
5	35355	Split Roll Pin

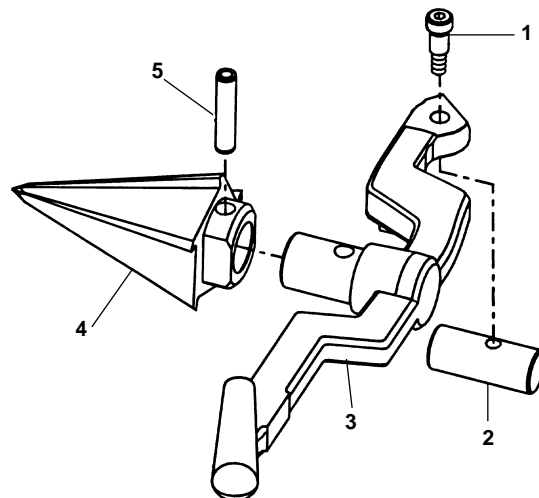

**52 RPM Electrical
120V 60Hz**

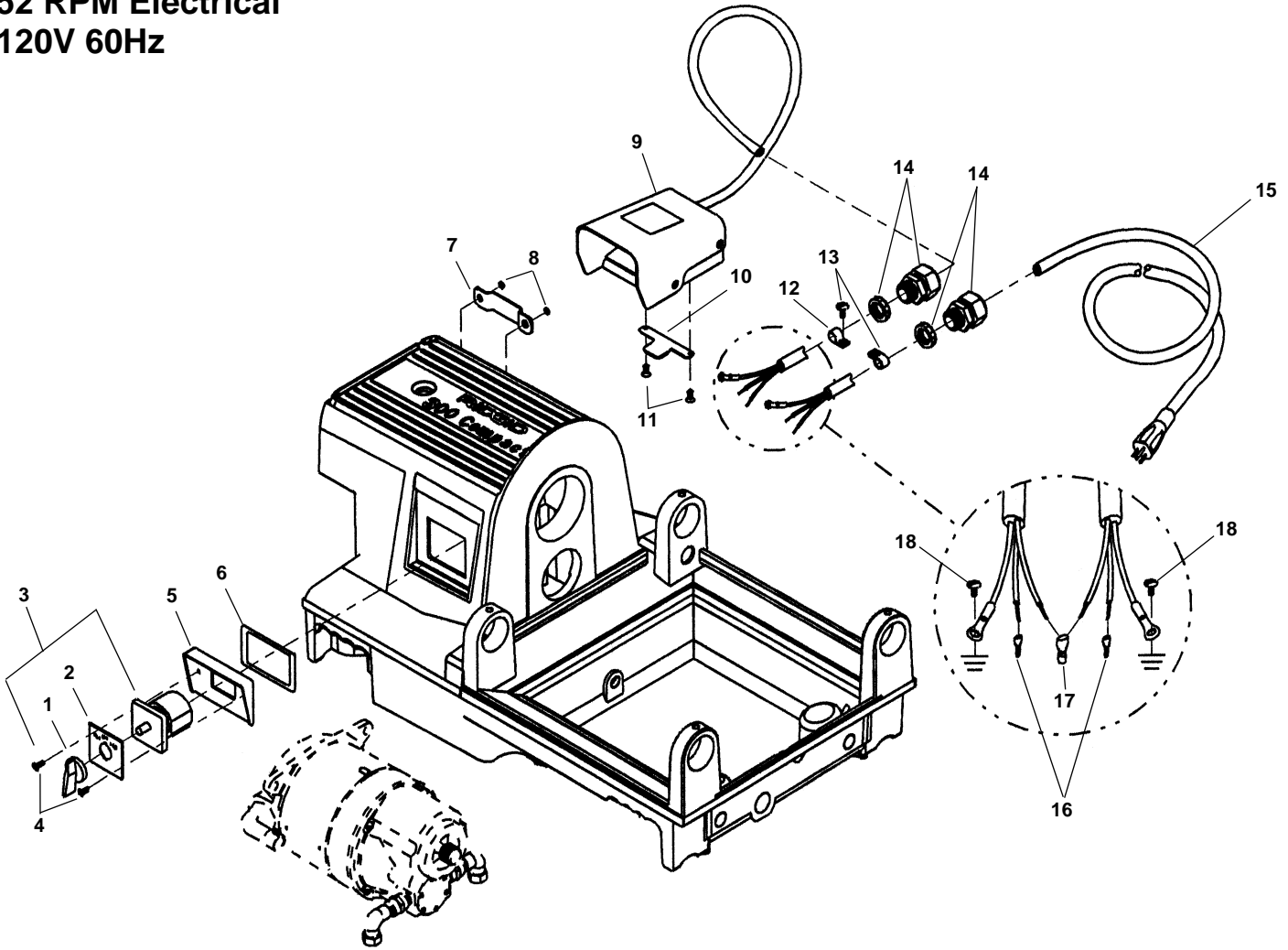

**NOTE: Order parts by Catalog Number only.
DO NOT order by Reference Number.**

Ref. No.	Catalog No.	Description	Ref. No.	Catalog No.	Description
1	61397	Switch Knob	10	58602	Foot Switch Hook
2	61967	Switch Face Plate	11	54357	Screw $\frac{3}{16}$ " - 18 (2)
3	54157	Switch Assembly	12	75937	Cable Clamp (2)
4	54162	Screw (2)	13	92455	Screw #10-24 x $\frac{3}{4}$ "
5	44695	Switch Plate	14	75952	Strain Relief with Nut
6	54172	Gasket	15	75972	Power Cord
7	58267	Foot Switch Hanger Bracket	16	76347	Wire Terminals (6)
8	54137	Screw (2)	17	44635	Wire End Splice
9	75962	B294 HD Foot Switch	18	45420	Grand Screw #10-24 x $\frac{3}{8}$ " (2)

Wiring Diagrams

115V Domestic

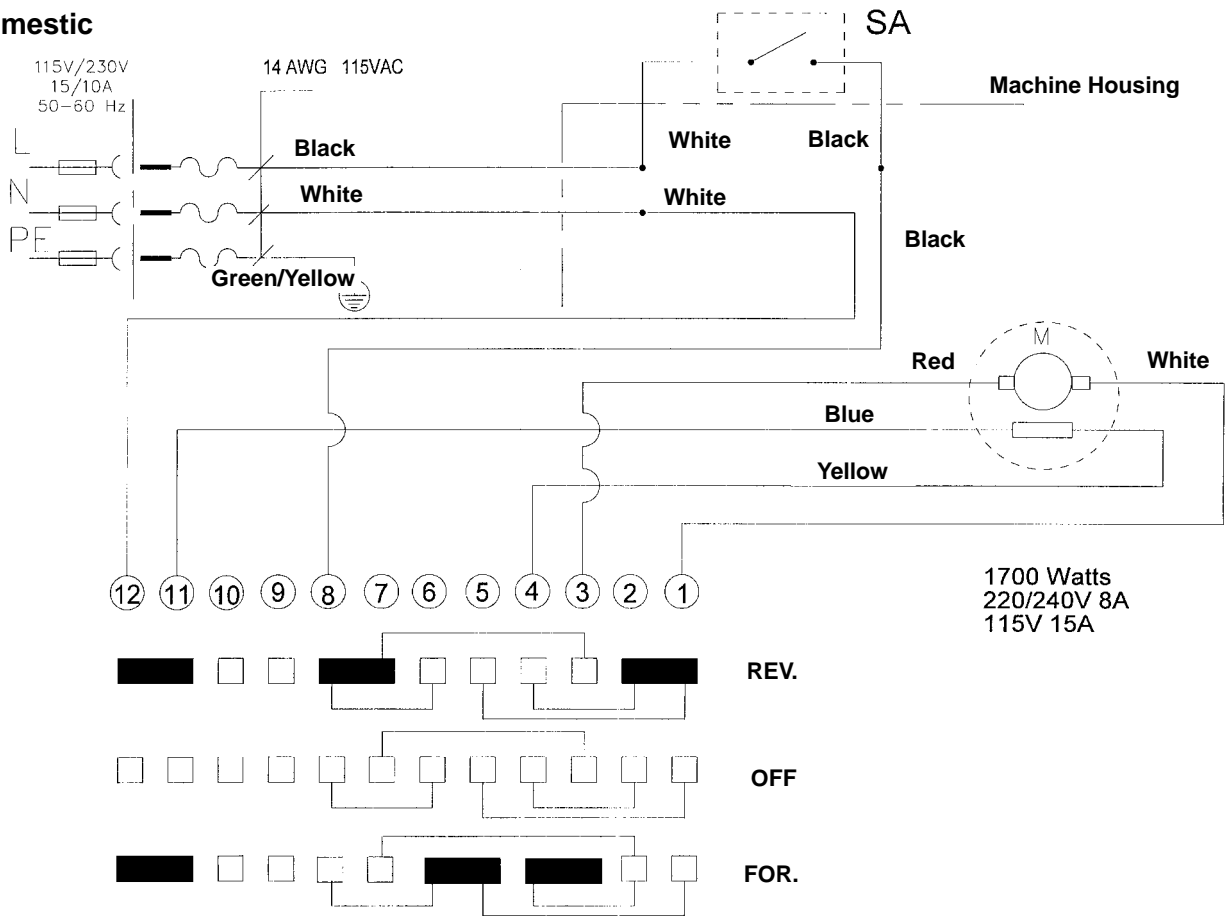

115V/230V 25-60 Hz

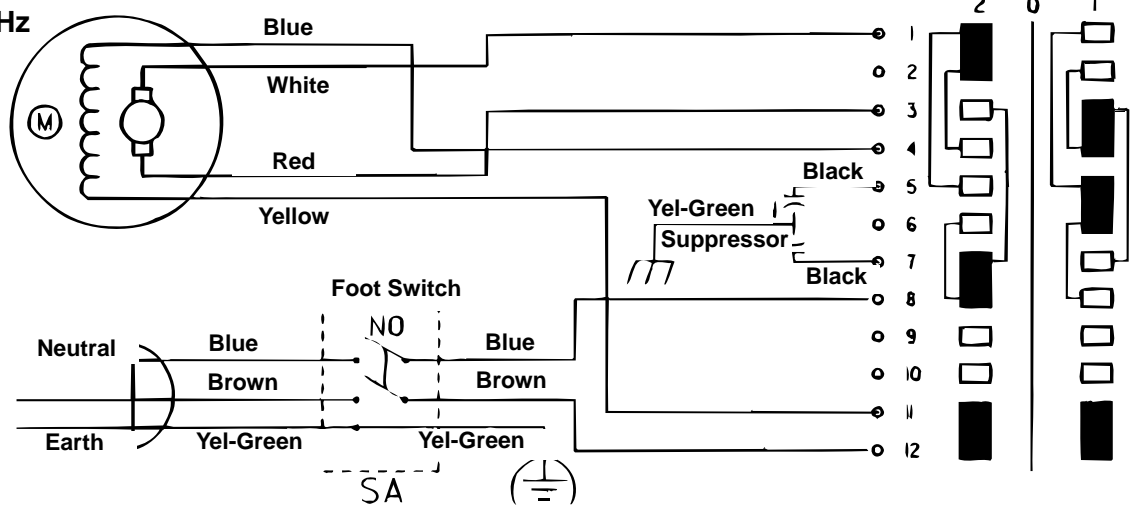

115/230V Far East

