

Main Components - Type 2/3

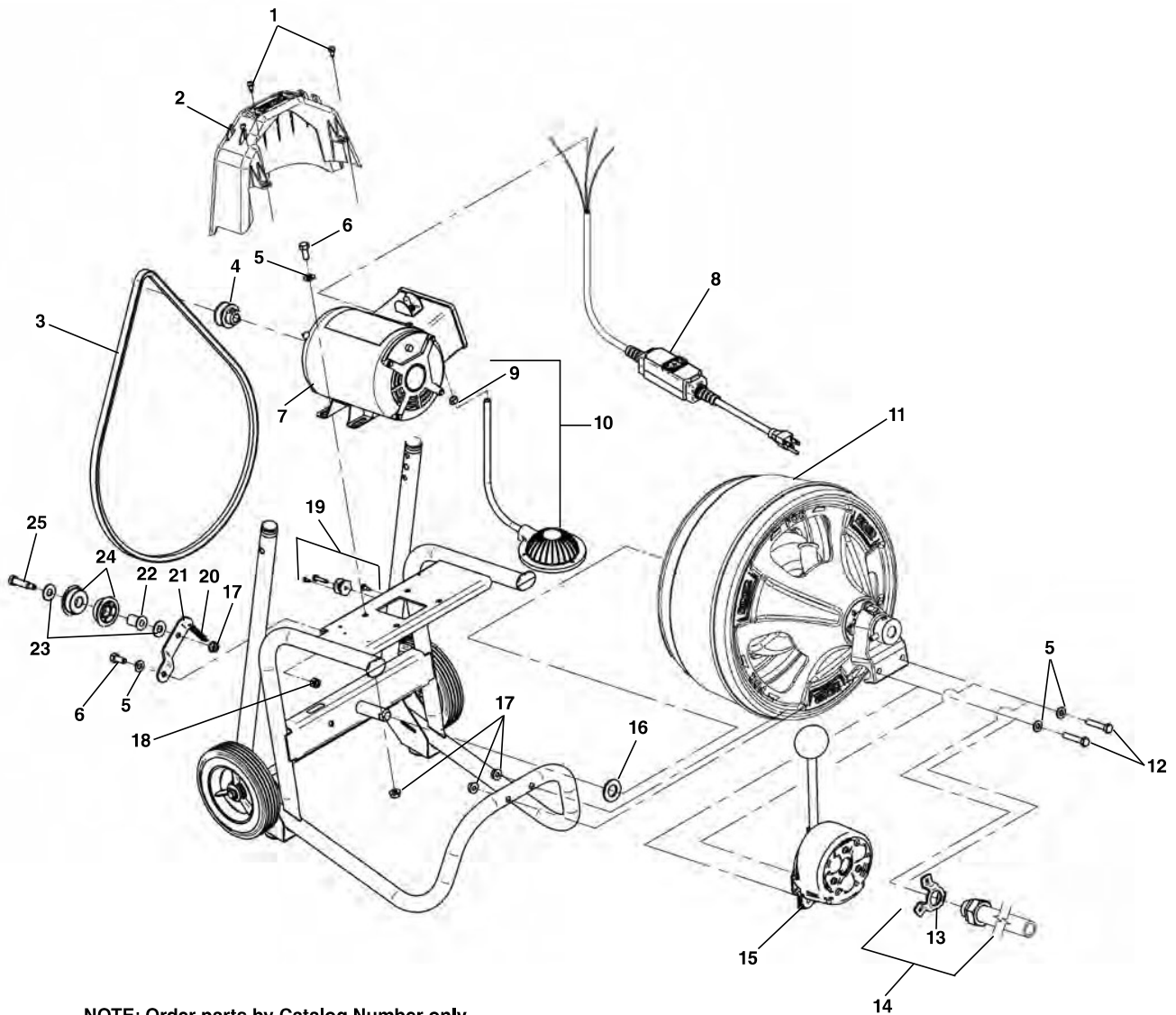

**NOTE: Order parts by Catalog Number only.
DO NOT order by Reference Number.**

Ref. No.	Catalog No.	Description	Ref. No.	Catalog No.	Description
1	70063	Screw #10-24 (3)	11	27048	Drum Assembly
2	27483	Belt Guard	12	91302	Hex Screw 5/16"-18 x 1 3/4" (2)
3	27498	V-Belt	13	27603	Guide Hose Mounting Bracket
4	27513	Pulley	14	26778	Guide Hose Assembly
5	60065	Flat Washer 5/16" (7)	15	52343	AUTOFEED® Assembly
6	59785	Hex Screw 5/16"-18 x 3/4" (5)	16	27608	Spacer
7	53333	Motor 120V 60Hz	17	27517	Lock Nut 5/16" (3)
	27623	Motor 220/240V 50Hz	18	27508	Hex Nut 5/16"
	27583	Motor 220V 50Hz Europe	19	30728	Torque Limiter Assy.
8	50497	GFI Power Cord 120V 60Hz	20	27523	Spring
	69783	Power Cord 220V Export	21	27533	Pulley Bracket
	67433	Power Cord 240V Australia	22	27493	Flange Bushing
	67428	Power Cord 220V Europe	23	33082	Flat Washer 5/16" (2)
9	35142	Hose Clamp	24	27488	Idler Pulley (2)
10	37967	Foot Switch	25	33627	Shoulder Screw 5/8" x 1 1/4"

Except 70068 Sleeve Bushing All Type 3 Parts Are Backwards Compatible.

Frame Assembly - Type 2/3

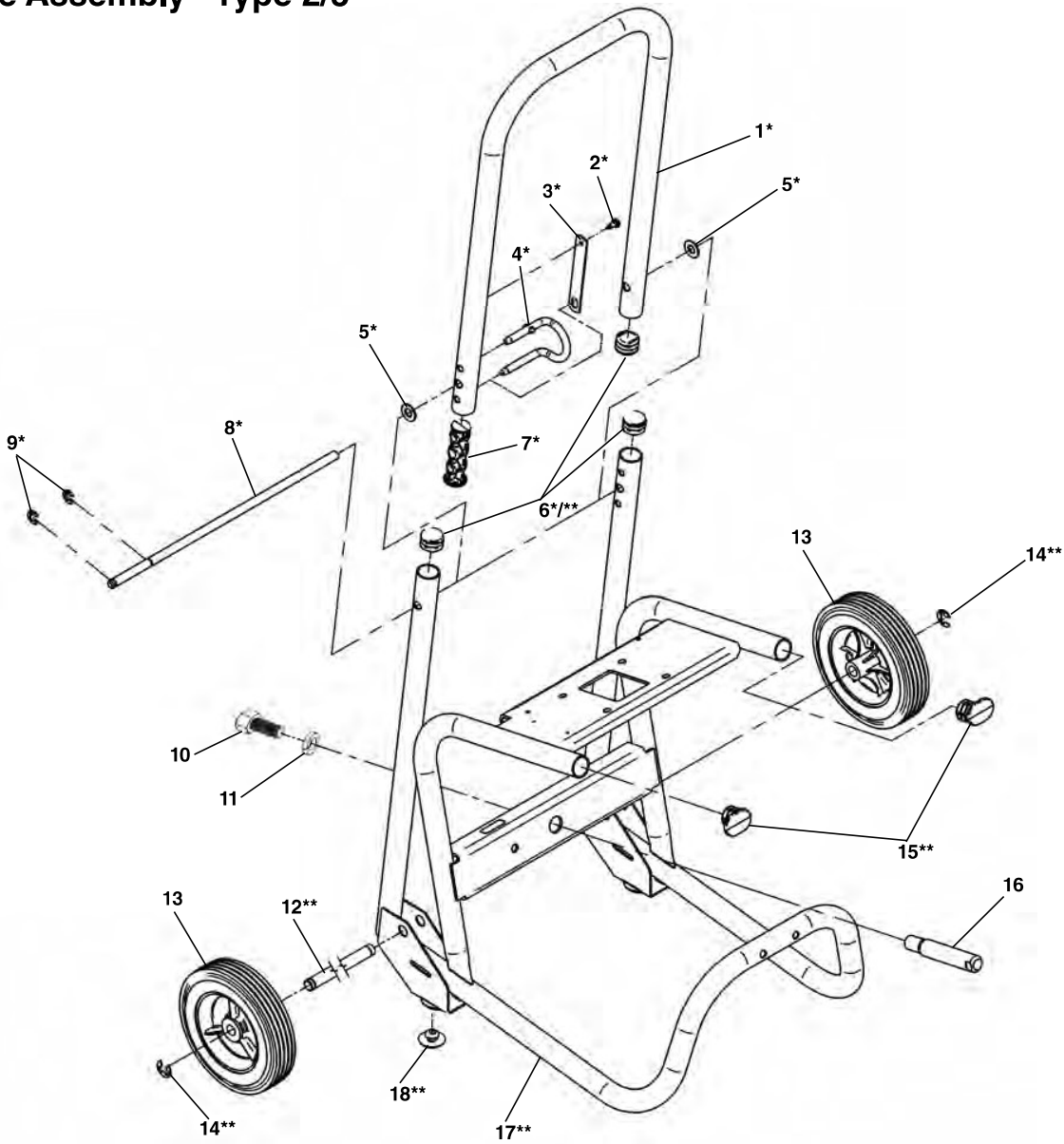

**NOTE: Order parts by Catalog Number only.
DO NOT order by Reference Number.**

Ref. No.	Catalog No.	Description	Ref. No.	Catalog No.	Description
1*	53323	Handle Only	10	70078	Screw, 1/2"-20 x 3/4"
	53518	Handle Assembly Complete	11	70073	Lock Washer 3/8"
2*	70063	Screw, #10-24 Pan Head	12**	27518	Wheel Axle
3*	53318	Flat Spring	13	60842	Wheel (2)
4*	53313	Bent Pull Pin 5/16"	14**	59810	Retaining Ring (2)
5*	59970	Flat Washer 3/8" (2)	15**	53348	Cord Wrap Cap (2)
6**	27558	Plug 1" (3)	16†	27463	Drum Shaft (Includes 10 & 11)
7*	27588	Bushing	17**	53398	Frame Assembly
8*	53353	Handle Axle	18**	27553	Rubber Foot (2)
9*	34245	Retaining Ring (2)			

* Included With 53518 Handle Assembly Complete

** Included With 53398 Frame Assembly

† Ref. 16 Drum Shaft Includes Ref. 10 & 11

Except 70068 Sleeve Bushing all Type 3 parts are backwards compatible.

Frame Assembly - Type 1

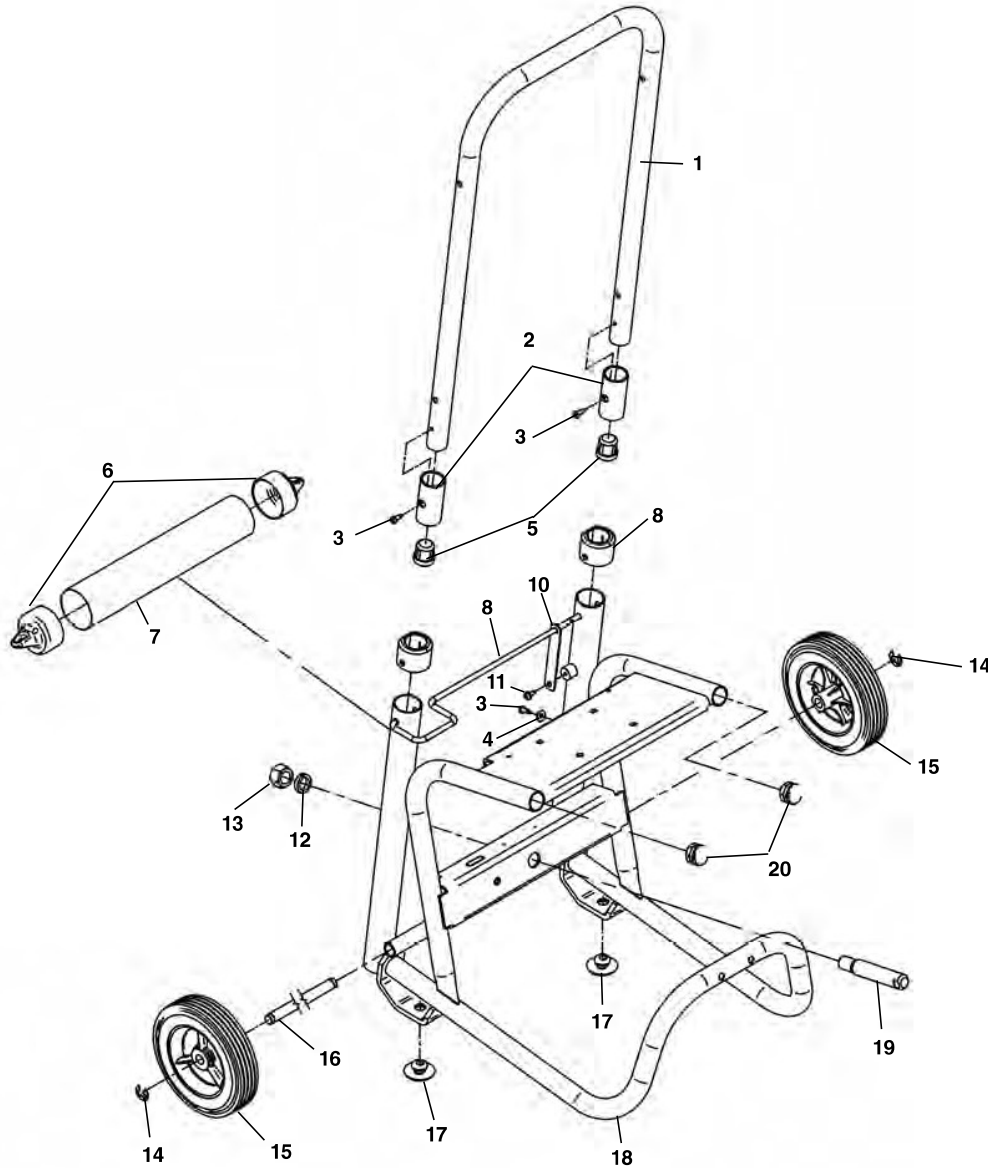

**NOTE: Order parts by Catalog Number only.
DO NOT order by Reference Number.**

Ref. No.	Catalog No.	Description	Ref. No.	Catalog No.	Description
1	27473	Handle	11	68937	Screw, #10-24 Pan Head (3)
2	27538	Handle Sleeve (2)	12	46682	Lock Washer 5/16"
3	45275	Screw, #10-24 x 1/2" Pan Head (3)	13	13617	Hex Nut 5/16" - 11
4	45365	Flat Washer #10	14	59810	Ring, Retaining (2)
5	27503	Rubber Foot (2)	15	60842	Wheel (2)
6	27593	Cap (2)	16	27518	Axle
7	27588	Tube f/Operator's Manual	17	27553	Grommet
8	27563	Bushing (2)	18	27438	Frame
9	27453	Release Lever	19	27463	Drum Shaft
10	27458	Flat Spring	20	27558	Plug 1" (2)

Drum Assembly

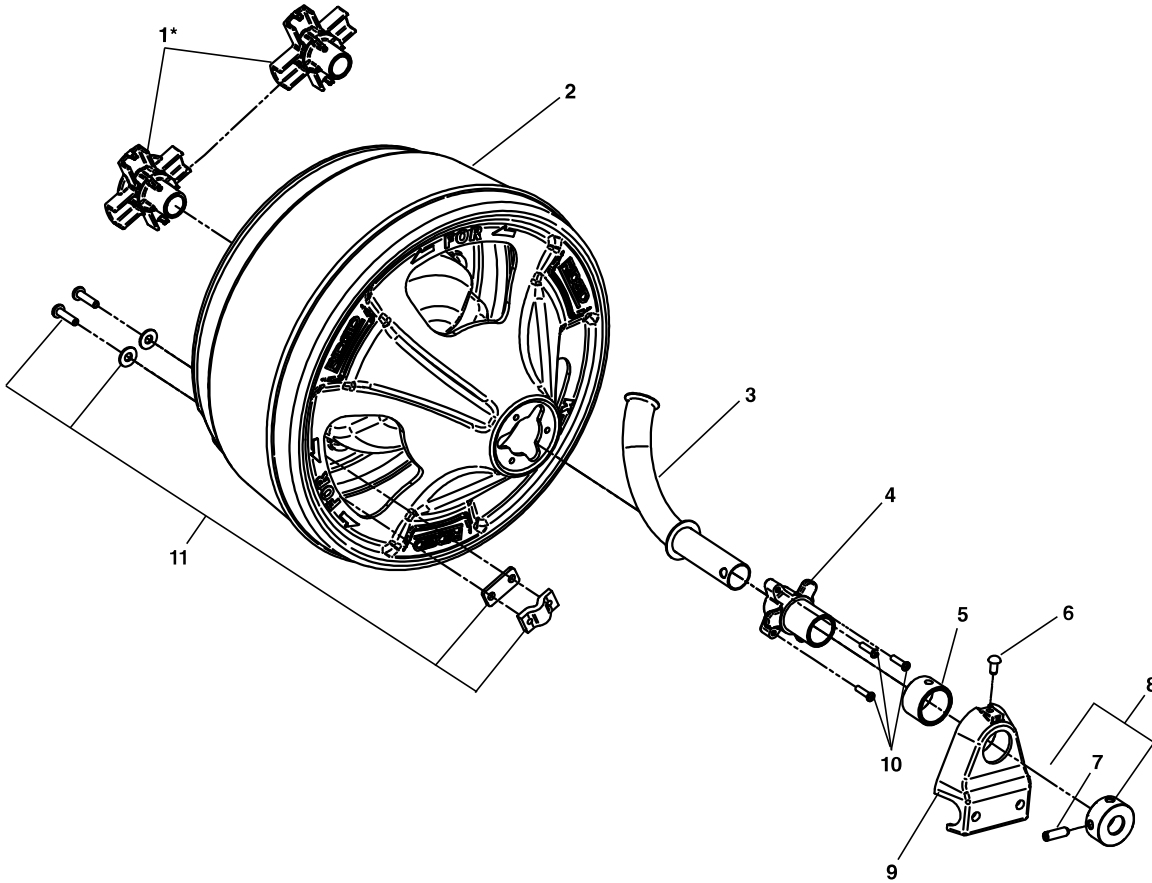

**NOTE: Order parts by Catalog Number only.
DO NOT order by Reference Number.**

Ref. No.	Catalog No.	Description
—*	27048	Drum Assembly
1*	27543	Sleeve Bushing T2
	70068	Sleeve Bushing T3
2	27528	Drum
3	27478	Guide Tube
4	27448	Guide Tube Bushing
5	27468	Sleeve Bushing
6	27548	Drive Screw
7	39582	Set Screw $\frac{3}{16}$ " x 1"
8	37912	Set Collar Assembly
9	27443	Bearing Support
10	27578	Screw #8 - 16 x $\frac{3}{4}$ " (3)
11	56147	Cable Clamp Assembly

*T2 & T3 Bushing Included With Drum Assembly.
Except 70068 Sleeve Bushing All Type 3 Parts
Are Backwards Compatible.

AUTOFEED® Assembly - Type 1/3

**NOTE: Order parts by Catalog Number only.
DO NOT order by Reference Number.**

Ref. No.	Catalog No.	Description
—	26773	AUTOFEED Assembly K-400 T1/3
1	60737	Hex Screw 5/16" - 18 x 3" (2) Lock
2	60080	Washer 5/16"
3	60065	Flat Washer 5/16"
4	27608	Spacer
5	87627	Mounting Bracket
6	87607	Roller Shaft (6)
7	59585	Ball For Handle
8	93630	Clutch Handle
9	87622	Back Plate
10	87617	Spring
11	44077	Bearing
12	41502	Set Screw 5/16" - 18 x 3/4" (3) Front
13	87612	Plate
14	87632	AUTOFEED Cover
15	45420	Screw 10 - 24 x 1/2" (3)
16	26773	AUTOFEED Assembly

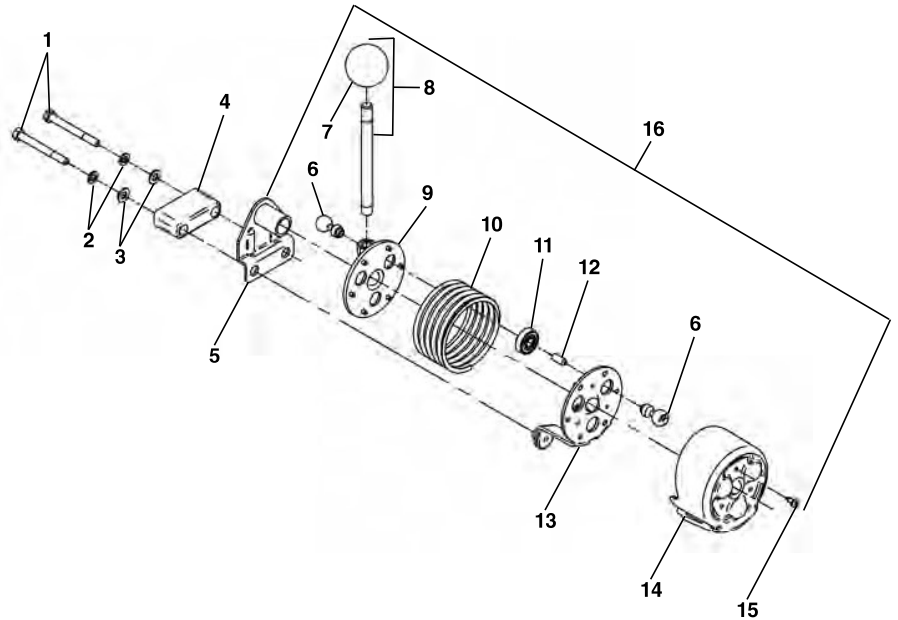

AUTOFEED® Assembly - Type 2

**NOTE: Order parts by Catalog Number only.
DO NOT order by Reference Number.**

Ref. No.	Catalog No.	Description
—	52343	K400 Autofeed Assembly
1	59585	Ball for Handle
2	93630	Clutch Handle
3	53358	Cover
4	43357	Flat Washer #10 (3)
5	68937	Screw #10 x 1/2" (3)
6	61130	Screw 5/16"-18 x 3/4" Hex (2)
7	60080	Lock Washer 5/16" (2)
8	53383	Mounting Bracket
9	53378	Bottom Roller Housing
10	53373	Hinge Pin 1/4"-20
11	53368	Spring
12	53363	Top Roller Housing
13	44760	Bearing (6)
14	26997	Screw 5/16"-16 x 3/4 Hex Soc BH (6)

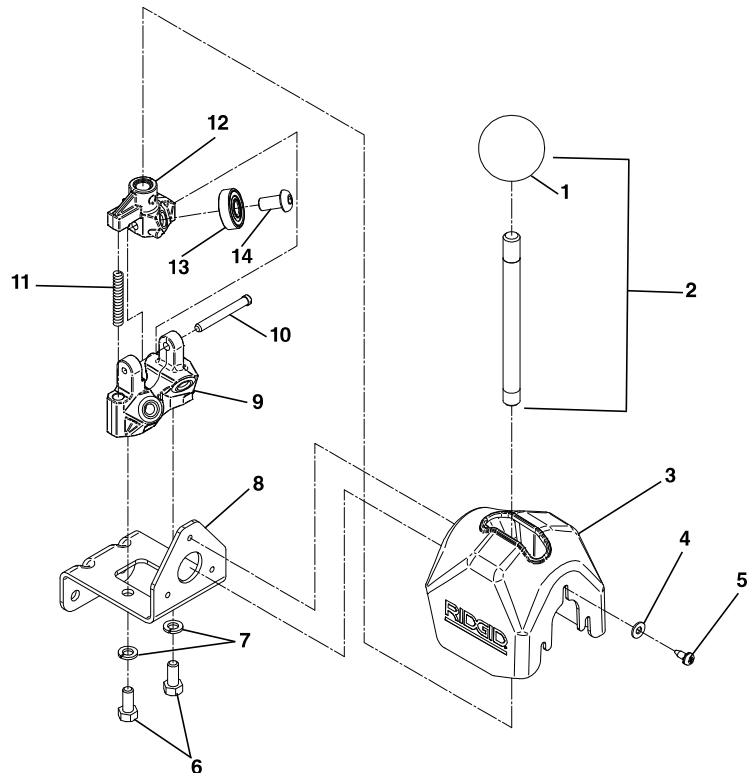

Guide Hose Assembly

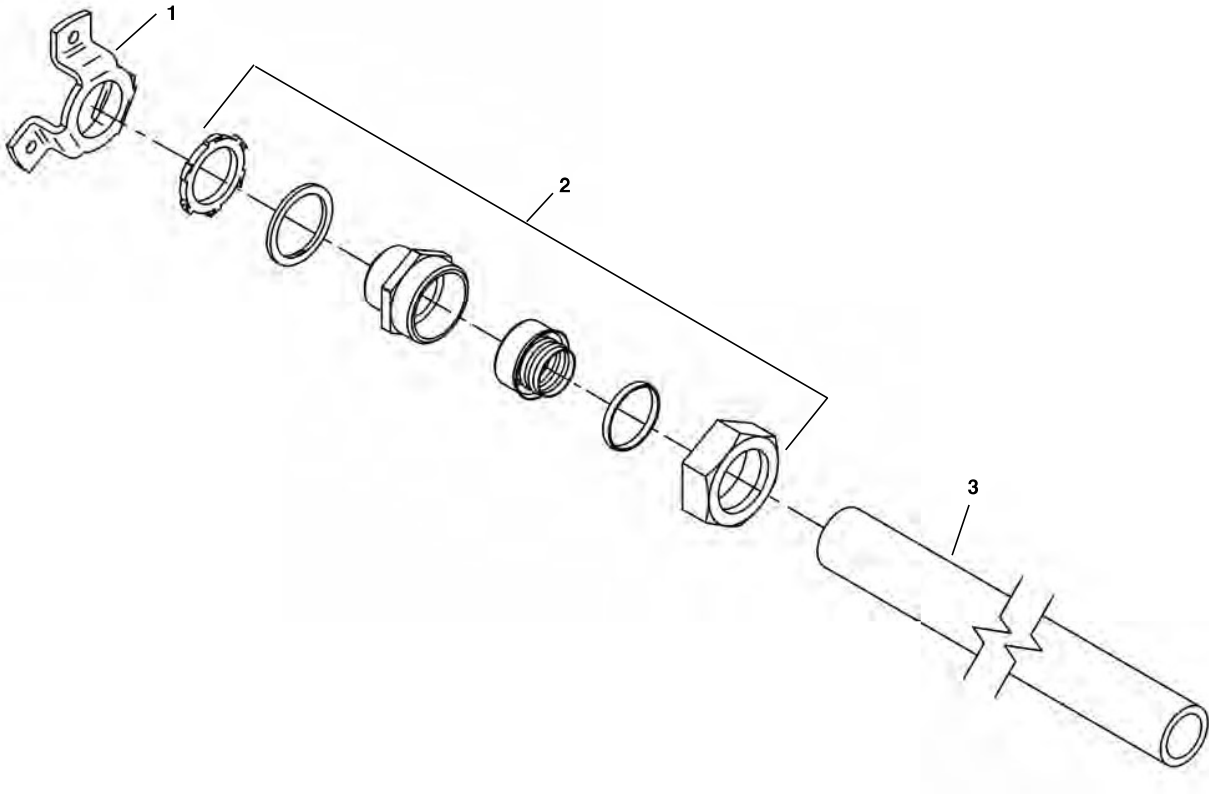

**NOTE: Order parts by Catalog Number only.
DO NOT order by Reference Number.**

Ref. No.	Catalog No.	Description
—	26778	Guide Hose Assembly
1	27603	Guide Hose Bracket
2	72477	Guide Hose Connector
3	27598	Hose 2'

Motor Components

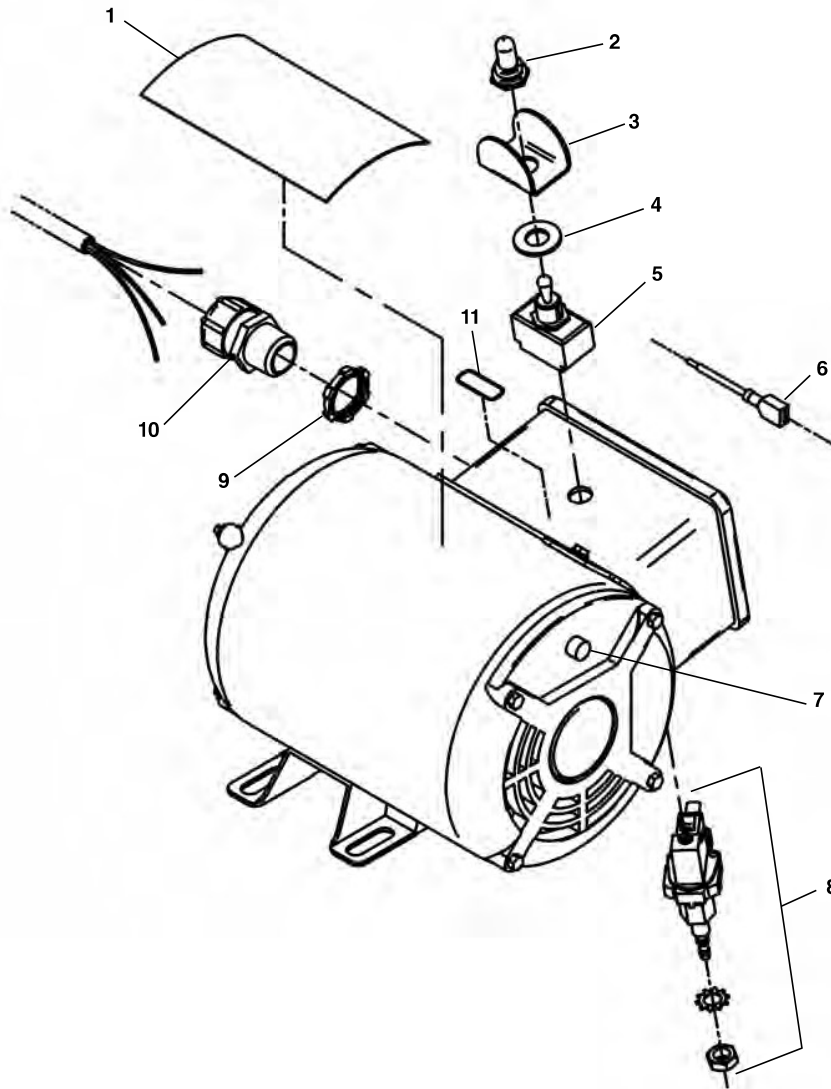

**NOTE: Order parts by Catalog Number only.
DO NOT order by Reference Number.**

Ref. No.	Catalog No.	Description
—	53333	120V 60Hz Motor Assembly
—	27623	220/240V 50Hz Motor Assembly
1	27618	Safety Decal
2	23507	Rubber Boot
3	61490	Switch Guard
4	23512	Rubber Washer
5	41817	Switch
6	44877	Lead Wire Assembly
7	55688	Thermal Overload
8	32992	Air Switch
9	65642	Lock Nut
10	96265	Strain Relief
11	23687	FOR/REV Label

Motor Components - 220V - 50Hz Europe

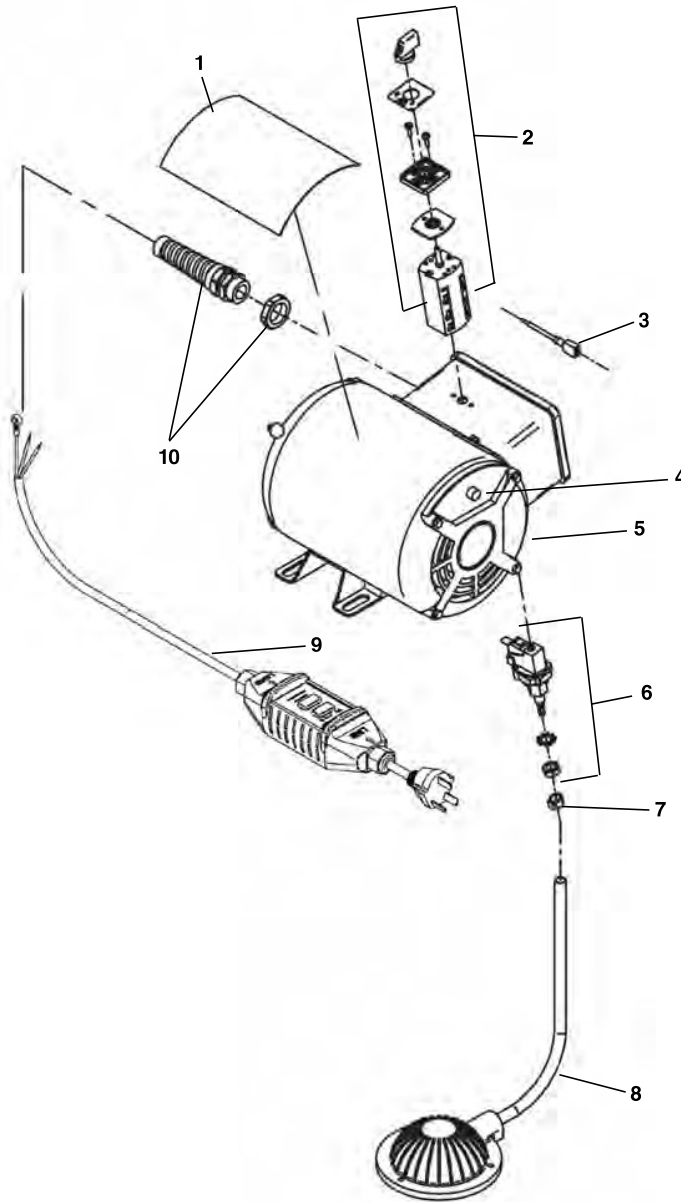

**NOTE: Order parts by Catalog Number only.
DO NOT order by Reference Number.**

Ref. No.	Catalog No.	Description
1	27618	Safety Decal
2	44862	Switch
3	44877	Lead Wire Assembly
4	67412	Thermal Overload
5	27583	220V 50Hz Motor Assy.
6	32992	Air Switch
7	35142	Hose Clamp
8	37967	Foot Switch Assembly
9	67428	220V Power Cord (Europe)
10	27187	Strain Relief

Wiring Diagrams

120V 60Hz

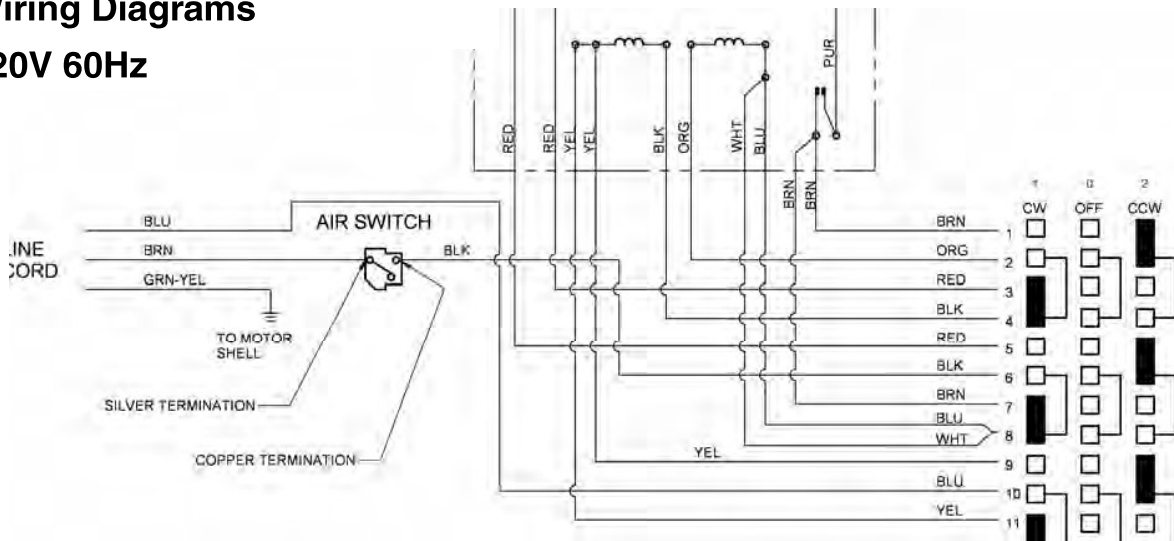

220/240V 50Hz Export

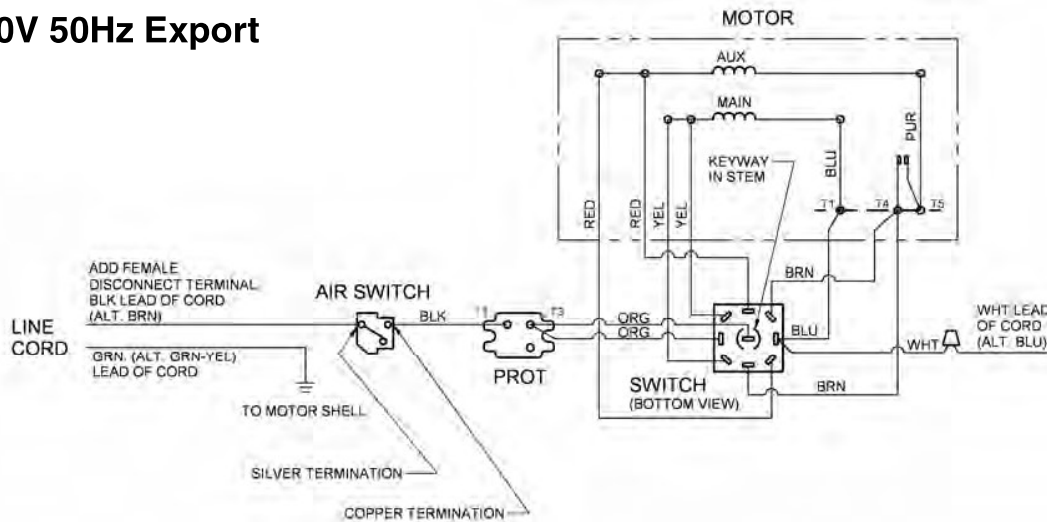

220V 50Hz Europe

